

**STP-H600/H1000 Series
Turbomolecular Pump
INSTRUCTION MANUAL
(Third Edition-d)**

Read through the Safety Precautions of this Manual carefully before using the STP pump.
Keep this Manual in a place where you can quickly access it at any time.

SAFETY PRECAUTIONS

The Safety Precautions in this Manual constitute guidelines to protect operators, the STP pump and its peripheral equipment.

To avoid personal injury and prevent product and/or peripheral equipment damage, observe the Safety Precautions as well as the general safety rules (your country's laws, regulations, safety standards and so on).

If the equipment is used in a manner not specified by the Seiko Instruments, the protection provided by the equipment may be impaired.

Symbols

The following symbols are used in this manual:



Death or Serious Personal Injury

Failure to follow the guidelines marked with this symbol may result in death or serious personal injury.



Minor Personal Injury, Product and/or Peripheral equipment Damage

Failure to follow the guidelines marked with this symbol may result in minor personal injury, product and/or peripheral equipment damage.



Items you must follow during operation and maintenance.

Symbols as Marked on the Equipment



ATTENTION : refer to this manual.

Seiko Instruments cannot perfectly anticipate circumstances of all of hazards or problems. The scope of anticipation is limited to the precautions included in the  and



specified in this manual.



Check the properties of the gas to be used, referring to the Material Safety Data Sheet (MSDS) you obtain from the gas supplier. Follow any and all safety precautions and/or recommendations instructed by the gas supplier.

Take appropriate measures specified in the MSDS to prevent a problem if you use any corrosive, reactive, flammable or other system gas. Dilute the pumped gas with a monitored inert gas if necessary. Take appropriate measures so as not to cause a problem due to the pumped gas

The STP pump is provided with a high-speed rotor. Secure the STP pump according to the specified method. Failure to do so may lead to serious personal injury, product and/or peripheral equipment damage if any abnormality/error occurs in the rotor.

The STP pump operates at high temperatures while the baking heater is in operation. NEVER touch the STP pump and its peripheral equipment while the baking heater is in operation.

Operators can burn hands.

Always exhaust residual gases thoroughly from the STP pump when removing the STP pump from the vacuum equipment. Residual gases in the STP pump may cause an accident which, for certain gases, may involve serious injury or death.

Confirm the characteristics of the gas to be used, referring to the Material Safety Data Sheet (MSDS) you obtain from the gas supplier. Wear personal protective equipment if necessary.

When covering the battery case, be sure not to catch the battery cable in the battery case. Failure to do so may short-circuit the battery and result in a leakage, production of fire or explosion.

NEVER throw the battery into fire nor heat it.

Failure to do so may result in an explosion, production of fire and/or serious personal injury. Observe the instructions given by the battery maker, the national and/or local government when disposing of the battery.

Exhaust residual gas thoroughly when disposing of the STP pump. If the STP pump is used for any toxic or reactive gas, always clean the STP pump and dispose of it as industrial waste in accordance with guidelines given by the national and/or local government.

Residual gas in the STP pump may cause an accident which, for certain gases, may involve serious injury or death.

Always remove the battery from the STP control unit when disposing of it. Failure to do so may result in fire or other accident.



NEVER use any gas that is not specified as usable in this Manual. The use of such gas may corrode the STP pump and damage it.

A hazardous live voltage may exist at connector/terminal that marked . DO NOT touch the terminal. Doing so may result in electric shock. When operating connection/disconnection to terminal, always power OFF the STP pump (Switch the breaker "OFF").

Always check the STP pump has stopped, then turn OFF the primary power (switch the breaker "OFF") before proceeding to any of the following operations. Failure to do so may cause the STP pump to rotate accidentally, which may injure operators seriously or result in electric shock.

- Connect or disconnect cables;
- Connect an external battery;
- Perform maintenance and inspections such as replacement of the internal battery and/or fuses as well as inspections of deposit and/or the air cooling fan (when replacing fuses, always disconnect the internal battery connector);
- Perform investigations into probable causes and action/measures taken in the event of occurrence of a problem; or
- Open and close the STP control unit front panel (hereinafter referred to as the front panel) in order to check or reset the "BATTERY NG" (hereinafter referred to as "BATTERY NG") lamp.

The STP pump and the STP control unit are heavy products. Always use a crane or the like when lifting them. When lifting the STP pump by hands for unavoidable reasons, it must always be lifted by two or more people. Failure to do so may damage their hipbone or injure them due to occurrence of an accident such as fall.

Install the STP control unit not only by fitting it with the front panel fitting screws but also by supporting it from the bottom side. Fitting the STP control unit with the screws only cannot sustain its weight, and therefore resulting in product damage.

Always use the STP pump, STP control unit and STP connection cables of the same model name, serial number and cable length, which are specified on their own name plate.

Failure to do so may result in product damage. If you use units with the same model name but different serial number and cable length; they must be adjusted. If the model names are different, they may not be used even when performing adjustment. In both cases, contact Seiko Instruments.

Use the STP connection cable and the motor connection cable that have a label affixed

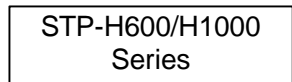

The use of different cables may result in product damage.

Connect the cables securely. NEVER bend nor place heavy objects on the cable. Doing so may result in electric shock or product damage.

Always use the power voltage specified on the name plate for the primary power voltage of the STP control unit. Wire the power cable securely. Incorrect wiring may result in electric shock or product damage.

NEVER remove the splinter shield from the STP pump. Doing so may result in product damage.



DO NOT put foreign objects into the STP pump. Doing so may result in product damage.

NEVER turn OFF the primary power (DO NOT switch the breaker "OFF") while the STP pump is rotating. Doing so may result in product damage.

Perform investigations into probable causes and remove them before restarting the STP pump in the event of occurrence of a problem. The use of the abnormal STP pump may result in product damage.

Always replace batteries once a year. Failure to do so, the battery backup operation may not run at the power failure.

DO NOT connect internal batteries and external batteries simultaneously. Failure to do so may result in product damage.

DO NOT move the STP pump and the STP control unit while the STP pump is in operation. Doing so may result in product damage.

INTRODUCTION

Thank you very much for purchasing Seiko Instruments's turbomolecular pump. The turbomolecular pump is designed to be installed in the vacuum equipment in to exhaust gases from it.

This manual covers all items necessary to ensure safe installation, operation and maintenance of the following series of the STP-H600/H1000 turbomolecular pump:

Model Name	Specification
• STP-H600	High-throughput type
• STP-H1000	High-throughput type
• STP-H600C	High-throughput type, chemical specific * ¹
• STP-H1000C	High-throughput type, chemical specific

For the specifications of other models of the STP-H600/H1000 pump series, contact Seiko Instruments.

In this manual, the above STP pump series is collectively referred to as the "STP pump."

APPLIED STANDARDS

The STP pump conforms to the following directives and standards:

Applied Directives

- EC Machinery Directive
- EC Electromagnetic Compatibility Directive
- EC Low Voltage Directive

Applied Standards

- EN292-1
- EN292-2
- EN60204-1
- EN55011 (class A)
- EN50082-2

Applied Standards (Only a some model)^{*2}

- UL3101-1,1993 (Electrical Equipment for Laboratory Use; Part 1 : General Requirements)

^{*1} Chemical specific: STP pump with anti-corrosive treatment (responding to chlorine, fluorine or other system gases)

^{*2} Contact Seiko Instruments about recognized model.

PRECAUTIONS

- 1) No part of this manual may be reproduced in any form by any means without prior written permission from Seiko Instruments.
- 2) Seiko Instruments pursues a policy of continuing improvement in design and performance of this product. The right is, therefore, reserved to vary specifications and design without notice. Understand that the product you purchased and its contents including specifications described in this manual may differ.

REQUEST

If you find inaccuracies or errors in this manual, advise your nearest sales representative office of Seiko Instruments or the following sections of them:

Seiko Instruments Inc.

Sales Office (Japan)

Seiko Instruments Inc. Vacuum Innovative Products Sales Department
1-8 Nakase, Mihama-ku, Chiba-shi, Chiba 261-8507 JAPAN

Telephone: <Vacuum Innovative Products Sales Department, Direct>

Domestic 043-211-1401
International + 81-43-211-1401

Facsimile: Domestic 043-211-8075
International + 81-43-211-8075

Manufacturer, Sales Office (Japan)

Seiko Instruments Inc. Vacuum Innovative Products Division
4-3-1 Yashiki, Narashino-shi, Chiba 275-0004 JAPAN

Telephone: <Vacuum Innovative Products Service Section, Direct>

Domestic 047-475-3123
International +81-47-475-3123

<Company main>

Domestic 047-475-3111
International +81-47-475-3111

Facsimile: Domestic 047-471-1544
International +81-47-471-1544

Copyright 2001 Seiko Instruments Inc. All rights reserved.

Vacuum Innovative Products Sales Department

1-8 Nakase, Mihama-ku, Chiba 261, Japan

Telephone: + 81-43-211-1401(Direct)

Facsimile: + 81-43-211-8075

LIMITED WARRANTY

This WARRANTY applies to the customer to whom Seiko Instruments has delivered this product.

1. WARRANTY PERIOD:

Seiko Instruments warrants this product against defects for a period of two (2) years from the date of delivery or during the period specified in the agreement made by and between the customer and Seiko Instruments.

2. ITEM WARRANTED:

- 1) This warranty applies only to the product delivered from Seiko Instruments to the customer.
- 2) If any defect is found during this period, Seiko Instruments will, at its option, repair or recondition the product free of charge. The costs for repair or replacement of the product after the warranty period has passed will be at the customer's own charge.

3. DISCLAIMER:

Seiko Instruments makes no warranty with respect to any damage occurred due to any of the following during the warranty period:

- 1) Handling, operation or maintenance other than that specified herein;
- 2) Failure to follow any of the warnings or cautions enumerated under

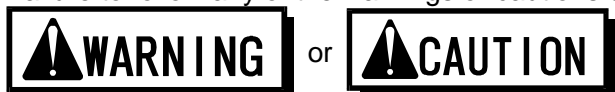

- 3) Installation, operation or maintenance using parts which are not specified by Seiko Instruments;
- 4) Maintenance personnel other than those authorized by Seiko Instruments or its specified plant have disassembled, reconditioned, or tampered the product;
- 5) Defect resulting from the not-specified use of the product;
- 6) When the product is used under special conditions without obtaining the written consent of Seiko Instruments (Particular gases, strong magnetic field and the radiation are added to the product.);
- 7) Defect resulting from deposit;
- 8) Water cooling system defect resulting from water quality used;
- 9) Defect resulting from the installation of the product (Exclude the installation by authorized personnel.);
- 10) Deterioration in the external because of use (Discoloration, scratches and so forth);
- 11) Product damage occurred during transport or other factors not attributable to Seiko Instruments;
- 12) Product breakage or damage due to natural disasters, fire or other external factors;
- 13) Deterioration in the basic performance due to the use of the product beyond limits of the use;
- 14) Any direct, incidental or consequential damage resulting from the use of the product;
- 15) When continuously operated without overhaul after the WARNING

indication (“WARNING” message) on the LCD display;

16) Overhaul and replacement of maintenance parts;

4. SPARE PARTS:

- Fuse and air cooling fan for control unit
- Touch down bearing
- Heater

TABLE OF CONTENTS

SAFETY PRECAUTION

INTRODUCTION

LIMITED WARRANTY

1	Precautions for Safe Operation of the STP Pump	1-1
1.1	Usable Gases.....	1-1
1.2	Maintenance Precautions.....	1-1
1.3	Inspection Precautions.....	1-2
1.4	Labels.....	1-2
2	Unpacking.....	2-1
2.1	Unpacking the STP Pump.....	2-1
2.2	Unpacking the STP Control Unit	2-2
3	Installation of the STP pump.....	3-1
3.1	Name and Function of Each Part.....	3-1
3.2	Precautions Before Installation	3-3
3.2.1	Operating Environment	3-3
3.2.2	Installation Area	3-4
3.2.3	Bench	3-4
3.3	How to Install the STP Pump	3-5
3.3.1	Cleaning the Seal.....	3-6
3.3.2	STP Pump Installation Positions.....	3-7
3.3.3	How to Secure the STP Pump	3-8
3.3.4	Vacuum Piping	3-12
3.3.5	Connecting the Emergency Vent. Valve	3-14
3.3.6	Connecting the Purge Port.....	3-14
3.3.7	Connecting the Ground Cable.....	3-15
4	Installation of the STP Control Unit.....	4-1
4.1	Name and Function of Each Part.....	4-1
4.1.1	Front Panel.....	4-1
4.1.2	Rear Panel	4-4
4.1.3	Inside of the STP Control Unit.....	4-6
4.2	Precautions Before Installation	4-8
4.2.1	Operating Environment	4-8
4.2.2	Installation Area	4-9
4.3	Attaching the STP Control Unit Front Panel to a Rack	4-10
4.4	Cable Connection.....	4-11
4.4.1	Name and Dimensions of Each Cable	4-11
4.4.2	How to Connect the Cables	4-13
5	How to Start/Stop the STP Pump	5-1
5.1	Before Starting	5-1
5.2	Starting/Stopping Time.....	5-1
5.3	Start Procedures	5-2
5.4	Stop Procedures	5-2
5.5	Manual Operation.....	5-3
5.5.1	Powering ON.....	5-3
5.5.2	Starting the STP Pump	5-3
5.5.3	Stopping the STP Pump.....	5-3

5.5.4	Starting the STP Pump after Stopping.....	5-3
5.5.5	Powering OFF.....	5-4
5.6	Remote Operation.....	5-5
5.6.1	Powering ON.....	5-5
5.6.2	Starting/Stopping the STP Pump.....	5-5
5.6.3	Starting the STP Pump After Stopping.....	5-5
5.6.4	Powering OFF.....	5-6
6	Safety Functions When an Abnormality/Error Occurs.....	6-1
6.1	Safety Functions.....	6-1
6.1.1	Power Failure.....	6-1
6.1.2	Abnormal State of Magnetic Bearing.....	6-3
6.1.3	Excessive Vibration.....	6-3
6.1.4	Inverter Overload.....	6-3
6.1.5	Overheating Inside the STP pump.....	6-3
6.1.6	Overheating Inside the STP Control Unit.....	6-3
6.1.7	Overspeed.....	6-3
6.1.8	Abnormal Battery Voltage.....	6-4
6.1.9	Failure of Brake.....	6-4
6.2	Restarting after Any Safety Function Operates.....	6-5
6.3	Operation of the Emergency Vent. Valve.....	6-7
7	Gas Suction, Cooling and Baking the STP Pump.....	7-1
7.1	Gas Suction.....	7-1
7.1.1	How to Introduce a Purge Gas.....	7-1
7.2	Cooling the STP Pump.....	7-2
7.2.1	Water Cooling Method.....	7-2
7.2.2	Air Cooling Method.....	7-3
7.3	Baking the STP Pump.....	7-4
7.3.1	Attaching a Baking Heater.....	7-4
7.3.2	Interlocking the STP Pump Operation with Baking.....	7-6
8	Remote Input/Output Signal Terminal Blocks.....	8-1
8.1	I/O TB2 Terminal Block.....	8-1
8.2	DC I/O TB3 Terminal Block.....	8-6
8.3	START STOP TB5 Terminal Block.....	8-8
8.4	START/STOP TB6 Terminal Block.....	8-9
9	Internal Battery.....	9-1
9.1	Life of the Internal Battery.....	9-1
9.2	Allowable Shelf Life of the Internal Battery.....	9-1
9.3	How to Charge the Internal Battery.....	9-2
9.4	BATTERY NG Lamp.....	9-3
9.5	How to Replace the Internal Battery.....	9-4
9.5.1	How to Replace the Battery Case.....	9-4
9.5.2	How to Replace the Battery in the Battery Case.....	9-6
9.6	How to Dispose of the Internal Battery.....	9-8
10	External Battery.....	10-1
10.1	Specifications for the External Battery.....	10-1
10.2	Installation of the External Battery.....	10-2
10.3	How to Charge the External Battery.....	10-3
10.4	How to Dispose of the External Battery.....	10-3
11	Operation Principle of the STP Pump.....	11-1

12	Maintenance and Inspection	12-1
12.1	Replacing the Internal Battery	12-1
12.2	Inspecting the Air Cooling Fan	12-1
12.3	Replacing the Fuses	12-2
12.4	Inspecting for Deposit	12-3
12.5	Overhaul.....	12-4
12.6	Transporting for Repair or Overhaul	12-5
13	Storage	13-1
13.1	The STP Pump.....	13-1
13.2	The STP Control Unit.....	13-2
13.3	Restarting Precautions.....	13-2
14	Disposal	14-1
14.1	The STP Pump.....	14-1
14.2	The STP Control Unit.....	14-1
14.3	The Battery.....	14-2
15	Troubleshooting	15-1
15.1	Troubleshooting Immediately After An Abnormality/Error Occurs	15-1
15.2	Abnormalities When Powering ON	15-2
15.3	Abnormalities When Performing The STP Pump Start Operation.....	15-3
15.4	Abnormalities While the STP Pump is Rotating.....	15-3
15.5	When Any Abnormality/Error Warning Lamp Lights	15-5
16	Specifications and Accessories	16-1
16.1	Specifications for the STP Pump	16-1
16.2	Specifications for the STP Control Unit.....	16-2
16.3	Accessories.....	16-4
16.4	Recommended Spare Parts.....	16-4

STP PUMP PROBLEM CHECK SHEET

UNIT CONVERSION TABLE

TABLES

Table 3.1	Tightening torque of bolt	3-8
Table 3.2	Maximum Torque predicted and Recommended securing bolt for inlet port flange	3-9
Table 3.3	Number of Claw Clamps by Size of Flange	3-10
Table 4.1	Connecting Primary Power Cable	4-15
Table 5.1	Starting/Stopping the STP Pump During Remote Operation	5-5
Table 6.1	State of Lamps and REMOTE Output Signal at Power Failure	6-2
Table 6.2	Operation of the STP Pump after Power Recovery	6-2
Table 6.3	Safety Functions	6-8
Table 7.1	Attaching Positions of the Cooling Unit and Baking Heater	7-5
Table 8.1	I/O TB2 Terminal Block	8-1
Table 8.2	Rated Contacts for Relays CR1 to 4, CR7, CR8 and CR10	8-4
Table 8.3	Rated Contacts for Relays CR5 and 6	8-4
Table 8.4	DC I/O TB3 Terminal Block	8-6
Table 8.5	START STOP TB5 Terminal Block	8-8
Table 8.6	START/STOP TB6 Terminal Block	8-9
Table 10.1	Specifications for the External Battery	10-1
Table 15.1	Troubleshooting After Powering ON	15-2
Table 15.2	Troubleshooting When Performing The STP Pump Start Operation	15-3
Table 15.3	Troubleshooting While the STP Pump Is Rotating	15-3
Table 15.4	Cross Reference of Items of Abnormality Warning Lamps	15-5
Table 15.5	Troubleshooting When Any of Abnormality/Error Warning Lamp Lights	15-6
Table 16.1	Specifications for the STP Pump	16-1
Table 16.2	Specifications for the STP Control Unit	16-2
Table 16.3	Accessories	16-4
Table 16.4	Recommended Spare Parts	16-4

FIGURES

Figure 2.1	Example of Lifting the STP Pump.....	2-1
Figure 3.1	Configuration of the STP Pump	3-2
Figure 3.2	Installation of the STP Pump to the Vacuum Equipment.....	3-5
Figure 3.3	STP Pump Installation Positions.....	3-7
Figure 3.4	Positions of the Outlet Port on the Horizontally or Slanted Installed STP Pump ..	3-7
Figure 3.5	Example of securing the STP pump (When securing the inlet port with bolts).....	3-9
Figure 3.6	Example of securing the STP pump (When securing the inlet port flange with claw clamps).....	3-10
Figure 3.7	Example of securing the STP pump (When installing the damper in the inlet port flange)	3-11
Figure 3.8	Connecting the Purge Port and Emergency Vent. Valve	3-15
Figure 4.1	STP Control Unit Front Panel	4-3
Figure 4.2	STP Control Unit Rear Panel	4-5
Figure 4.3	Inside of the STP Control Unit	4-7
Figure 4.4	Peripheral Space of the STP Control Unit	4-9
Figure 4.5	Example of Securing the STP Control Unit.....	4-10
Figure 4.6	External Dimensions of Each Cable	4-11
Figure 4.7	External Dimensions of the Power Cable	4-12
Figure 4.8	How to Secure Primary Power Cable	4-16
Figure 8.1	I/O TB2 Remote Output Signal Terminal Block	8-3
Figure 8.2	Example of Connecting I/O TB2 R. Pump Terminal.....	8-5
Figure 8.3	Example of Securing the Remote Cable.....	8-5
Figure 8.4	DC I/O TB3 Remote Input Signal Terminal Block.....	8-7
Figure 8.5	START STOP TB5 Remote Input Signal Terminal Block.....	8-8
Figure 8.6	START/STOP TB6 Remote Input Signal Terminal Block.....	8-9
Figure 9.1	Life of the Internal Battery.....	9-2
Figure 9.2	Allowable Shelf Life of the Internal Battery	9-2
Figure 9.1	How to Replace the Internal Battery	9-7
Figure 11.1	Cross Sectional View of the STP Pump	11-2
Figure 16.1	External Appearance of the STP Pump (Example: STP-H1000 Series)	16-5
Figure 16.2	External Appearance of the STP Control Unit	16-6
Figure 16.3	Label Affixing Positions for the STP Pump.....	16-7
Figure 16.4	Label Affixing Positions for the STP Control Unit	16-8
Figure 16.4	Label Affixing Positions for the Special Accessory	16-9

1 Precautions for Safe Operation of the STP Pump

1.1 Usable Gases

Chlorine or fluorine system gases can be used in chemical specific pumps (STP-H600C/H1000C or other models). When you use gases including alkaline metals, but excluding Li, gases including Ga, Hg, In, or Sn, or HBr, contact Seiko Seiki.



Check the properties of the gas to be used, referring to the Material Safety Data Sheet (MSDS) you obtain from the gas supplier. Follow any and all safety precautions and/or recommendations instructed by the gas supplier.

Take appropriate measures specified in the MSDS to prevent a problem if you use any corrosive, reactive, flammable or other system gas. Dilute the pumped gas with a monitored inert gas if necessary. Take appropriate measures so as not to cause a problem due to the pumped gas



NEVER use corrosive gases (chlorine, fluorine, or other system gases) in the STP-H600/STP-H1000 pump or other models without anti-corrosion treatment.

Introduce a dry N₂ gas (purge gas) to protect the inside of the STP pump when using reactive or corrosive gases.

Cool the STP pump to within the operating pressure range to prevent the STP pump from overheating when sucking gases.

1.2 Maintenance Precautions

Perform any maintenance of the STP pump and the STP control unit (battery replacement, fuse replacement), following Section 12, "Maintenance and Inspection".



Always turn OFF the primary power (switch the breaker "OFF") before performing any maintenance.

Disconnect internal battery connector before performing maintenance of the STP control unit.

NEVER touch any portions other than those designated when performing maintenance.

Careless touch may cause electric shock and/or a short-circuiting of the internal circuit, resulting in product damage or a problem.

1.3 Inspection Precautions

Perform inspections of the STP pump and the STP control unit (check of the air cooling fan and reset of the "BATTERY NG" lamp), following Section 12, "Maintenance and Inspection" When performing inspections (check of the air cooling fan and reset of the "BATTERY NG" lamp), always turn OFF the primary power (switch the breaker "OFF") before opening the front panel, then turn ON the primary power again (switch the breaker "ON").





NEVER touch any portions other than those designated when performing inspections.
Careless touch may cause electric shock and/or a short-circuiting of the internal circuit, resulting in product damage or a problem.

1.4 Labels

The following labels are affixed to the STP pump and STP control unit.
Read the contents of the labels before operation. For the positions of the labels, see Figures "Label Affixing Positions".



(1) STP Pump Caution Label

This label describes precautions for operating the STP pump.
Follow these precautions.

 注意	 CAUTION
<ul style="list-style-type: none"> ◇必ず指定の型式のケーブルを使用してください。 ◇最初にアース線を接続してください 	<ul style="list-style-type: none"> ◇Use only designated type of cables. ◇Connect ground cable first.

(2) STP Control Unit Caution Label

This label describes precautions for operating the STP control unit.
Follow these precautions.

 注意	 CAUTION
<ul style="list-style-type: none"> ◇ポンプとコントロールユニットおよび接続ケーブルは同一Noの組合せで使用してください。 ◇必ず指定の型式のケーブルを使用してください。 ◇最初にアース線を接続してください。 	<ul style="list-style-type: none"> ◇Use pump, control unit and connection cable with same serial number. ◇Use only designated type of cables. ◇Connect ground cable first.

(3) Heavy Product Caution Label

This label is affixed to the product with a mass of 20 kg or more.
Follow the precautions of Section 2, "Unpacking" so as not to cause any accident during handling.

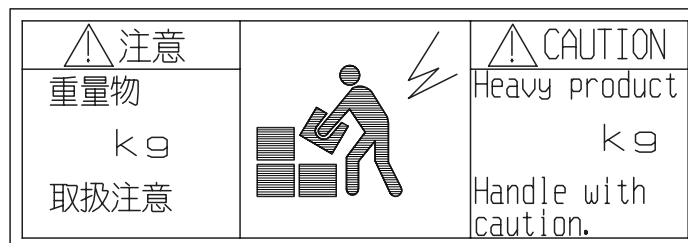

(4) STP Pump Installation Warning Label

This label describes installation of the STP pump.
Install the STP pump according to the precautions of Section 3, "Installation of the STP Pump."



(5) Emergency Vent. Valve Caution Label

This label describes the emergency vent. valve installation position.
Connect the emergency vent. valve before use.

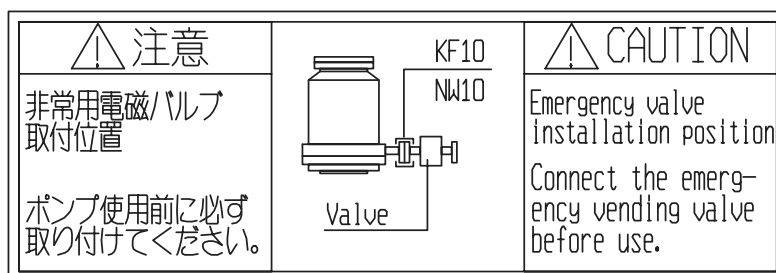

(6) Connector Caution Label

This label describes lock of the connector.

This label instructs operators to prevent the connectors from being disconnected while the STP pump is in operation.

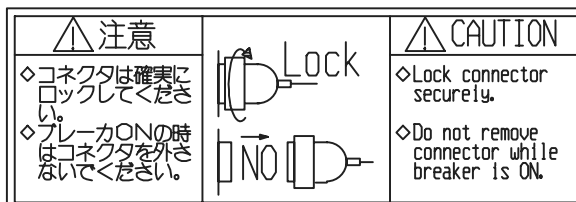

(7) STP Control Unit Safety Instruction Label

This label describes instructions before operating the STP control unit.

安全上の指示事項	SAFETY INSTRUCTIONS
使用前に取扱説明書をお読みください。	Read instruction manual before operation.

(8) High Voltage Device Caution Label

The STP control unit is equipped with a high voltage device. This label warns operators to pay attention to the high voltage device.

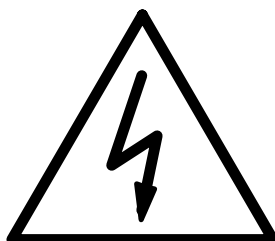

(9) Battery Instruction Label

This label instructs operators to replace batteries once a year.
 The next replacement date of batteries is specified upon delivery of the STP pump.
 Record the next replacement date (after one year) of batteries in the blank of the label when replacing them.
 This label describes precautions for use of external batteries.

⚠ 注意		⚠ CAUTION	
◇バッテリーは1年毎に交換してください。		◇Change batteries every year.	
◇内部バッテリーと外部バッテリーを同時に使用しないでください。		◇Do not use external batteries in combination with internal batteries.	
次回交換日/Next exchange date			

(10) Rotational Direction Instruction Label

This label describes the rotational direction of the STP pump.
 The STP pump rotates in this direction.



(11) Voltage Rating Label

This label describes the rated voltage of the STP control unit.
 Use voltage specified in this label.

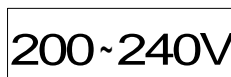

(12) Hot Surface Warning Label

This label instructs operators so as not to touch the hot surface of the STP pump.
 The use of the baking heater (optional accessory) may lead to a considerable rise in temperatures outside the STP pump.
 This label warns operators so as not to burn hands.
 (only when using the baking heater.)

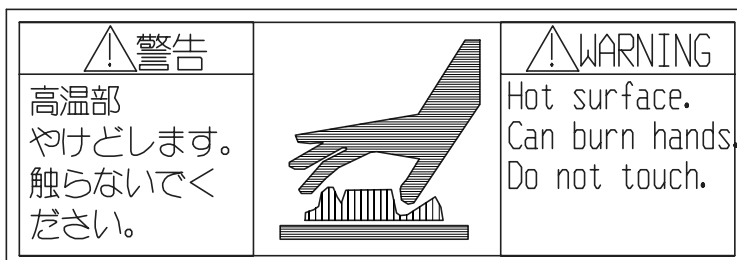

(13) Tuning Caution Label

This label describes precautions for performing the tuning.
 Tuning should be performed by Seiko Seiki trained or authorized personnel only.



2 Unpacking

2.1 Unpacking the STP Pump

Check the following before unpacking the STP pump.

- 1) Check the package for bruises, breakage, wetness, etc.
If there is any abnormality/error or it is judged necessary to return the product, contact Seiko Seiki.
- 2) Check the contents of the package.
See Section 16.3, "Accessories."



The mass of the STP pump is approx. 30 kg. Use a crane or other appropriate means to lift the STP pump.
Lift the STP pump with an eyebolt or a similar tool that uses the fitting hole attached to the inlet port flange.
Lift it with the aid of a suspension tool under the base when installing the STP pump without fitting hole.

Observe national laws/regulations, safety standards and so on when lifting the STP pump.

Use a crane or other appropriate means sufficient enough to withstand the load when lifting the STP pump.

Always lift the STP pump in stable places free of excessive shock or vibration to prevent it from shaking or dropping.

Have at least two people lift the STP pump when doing so by hand.



Be careful not to scratch the flange of the STP pump.
Before installing the STP pump, check whether or not there are scratches on the surface.

It is recommended to keep the packaging materials, such as the corrugated fiberboard container and cushioning material for possible reuse.

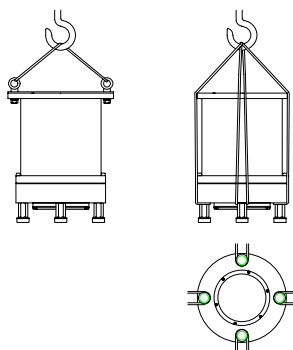

Figure 2.1 Example of Lifting the STP Pump

2.2 Unpacking the STP Control Unit

Check the following before unpacking the STP control unit.

- 1) Check the package for bruises, breakage, wetness, etc.
If there is any abnormality/error or it is judged necessary to return the product, contact Seiko Seiki.
- 2) Check the contents of the package.
See Section 16.3, "Accessories."



The mass of the STP control unit is approx. 40 kg. Use a crane or appropriate means to lift the STP control unit.

Lift the STP control unit using the two handles attached to the front panel.

Observe national laws/regulations, safety standards and so on when lifting the STP control unit.

Use a crane or appropriate means sufficient enough to withstand the load when lifting the STP control unit.

Always lift the STP control unit in stable places free of excessive shock or vibration to prevent it from shaking or dropping.

Have at least two people lift the STP control unit when doing so by hand.



It is recommended to keep the packaging materials, such as the corrugated fiberboard container and cushioning material for possible reuse.

3 Installation of the STP pump

3.1 Name and Function of Each Part

(1) Inlet Port Flange (ICF*1, VG*2, ASA, ISO, etc.)

- Connected to the vacuum equipment (at the high vacuum side).



A splinter shield is attached to the inlet port flange to prevent foreign particles from falling into the STP pump.
NEVER remove it.

(2) Outlet Port Flange (KF*2 40)

- Connected to the inlet port side of the auxiliary pump.

(3) STP Connector (41 pins)

- Connected to the STP connection cable.

(4) Motor Connector (5 pins)

- Connected to the motor connection cable.

(5) Purge Port (KF*2 10)

- Introduces a purge gas.
In order to protect the inside of the STP pump when sucking reactive or corrosive gases.
The STP pump is delivered with a blank flange attached to this port.

(6) Cooling Water Port (PT*2 (R/C)1/4 Female Screw)

- Connected to the STP pump cooling water pipe.
This port is used when water cooling the STP pump.

(7) Emergency Vent. Valve

- Protects the STP pump.
It functions immediately after any abnormality/error occurs inside the STP pump.

(8) Ground Terminal

- Used for grounding.
Connect the ground cable between this terminal and the ground terminal of the STP control unit .

The ground terminal is marked with label .

(9) Temperature Sensor Connector (optional accessory)

- A temperature sensor is attached.
For use with the Temperature Management System (TMS) unit only.

*1: JVIS

*2: JIS

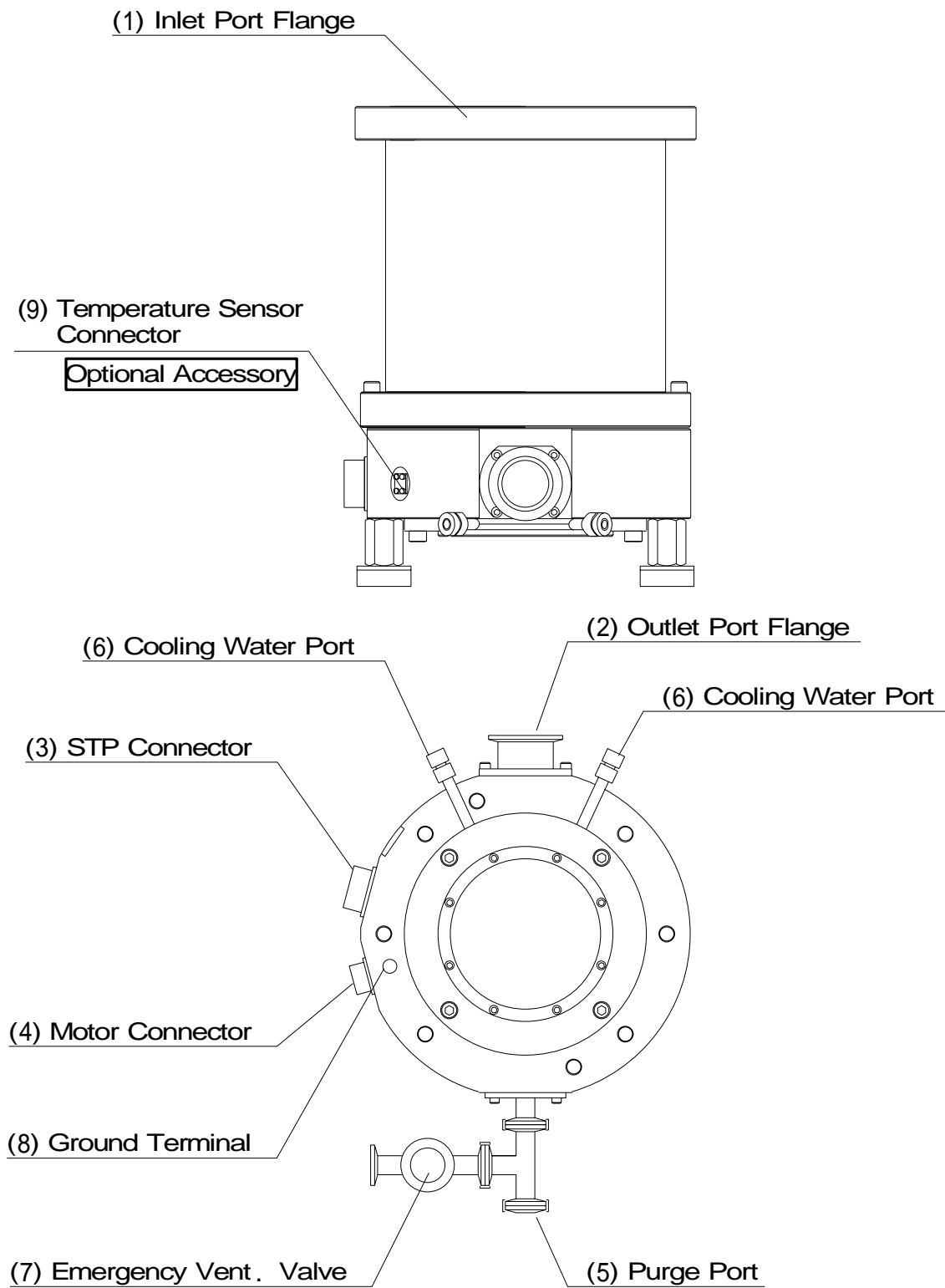

Figure 3.1 Configuration of the STP Pump

3.2 Precautions Before Installation

3.2.1 Operating Environment



Chlorine or fluorine system gases can be used in chemical specific pumps (type C). When you use gases including alkaline metals, but excluding Li, gases including Ga, Hg, Sn, or HBr, contact Seiko Instruments.

NEVER use corrosive gases (chlorine, fluorine, or other system gases) in the STP-H600/STP-H1000 pump or other models without anti-corrosion treatment (see Section 1.1, "Usable Gases").

Install the STP pump in a place meeting the following requirements:

Ambient Temperature	0 to 40 °C
Ambient Relative Humidity	30 to 95 % (no dew condensing)
Environment	<ul style="list-style-type: none"> ● A place free of externally-applied mechanical shock. ● A place free of a heat source (Keep clean of the heat source or attach a thermal shield plate). ● A place free of a strong magnetic field (Range: up to 15mT (150G) in the axial direction, and up to 3mT (30G) in the radial direction with respect to the rotational axis of the STP pump). ● A place free of a strong electric field. ● A place free of exposure to radiation. ● No discharge of high voltage (more than 500 V) (If more than 500 V is discharged, contact Seiko Instruments).
STP Pump Installation Equipment Conditions	<ul style="list-style-type: none"> ● Install the STP pump securely so that foreign particles will easily fall into the STP pump (Ex.: Si wafers or samples are positioned above the STP pump) (To prevent foreign particles from falling into the STP pump, design a shield plate with large conductance).

3.2.2 Installation Area

Leave enough space for the following in addition to that for the STP pump:

- Space for maintenance and inspection
- Space for connecting cables



The minimum bending radius of the STP connection cable is 150 mm (see Figure 16.1, "External Appearance of the STP Pump" [bending dimensions of the STP connection cable]).

DO NOT excessively bend the cables and beware of any obstacles when installing the STP pump.

Also, leave enough space to install other cables without bending them excessively.

3.2.3 Bench

A bench must be prepared by the customer to secure the STP pump. The shape and size of the bench differ depending upon the type of STP pump. Follow the precautions of the WARNING, CAUTION, or NOTICE (See Section 3.3.3, "How to Secure the STP Pump").



The STP pump is provided with a high-speed rotor. Any internal abnormality/error may result in a jump in rotational torque leading to personal injury or peripheral equipment damage.

Design and secure the bench for the STP pump so that it can withstand the maximum torque generated due to the occurrence of an abnormality/error.

Refer to Section 3.3.3 "How to Secure the STP Pump" for abnormal torque.



Secure the customer-prepared bench and the vacuum equipment on the floor or peripheral equipment and other equipment in accordance with the customer application. NEVER move them while the STP pump is in operation.

Use fitting bolts with a strength equal to or higher than SUS 304^{*1}. (Tensile strength class^{*1}: 50 or more as a target)



The screw hole for leg for securing the STP pump is M12^{*1}, and the depth is 24mm (8 positions).

For the external appearance of the STP pump, see Figure 16.1, "External Appearance of the STP Pump."

^{*1}:JIS

3.3 How to Install the STP Pump

Install the STP pump to the vacuum equipment as shown in Figure 3.2.

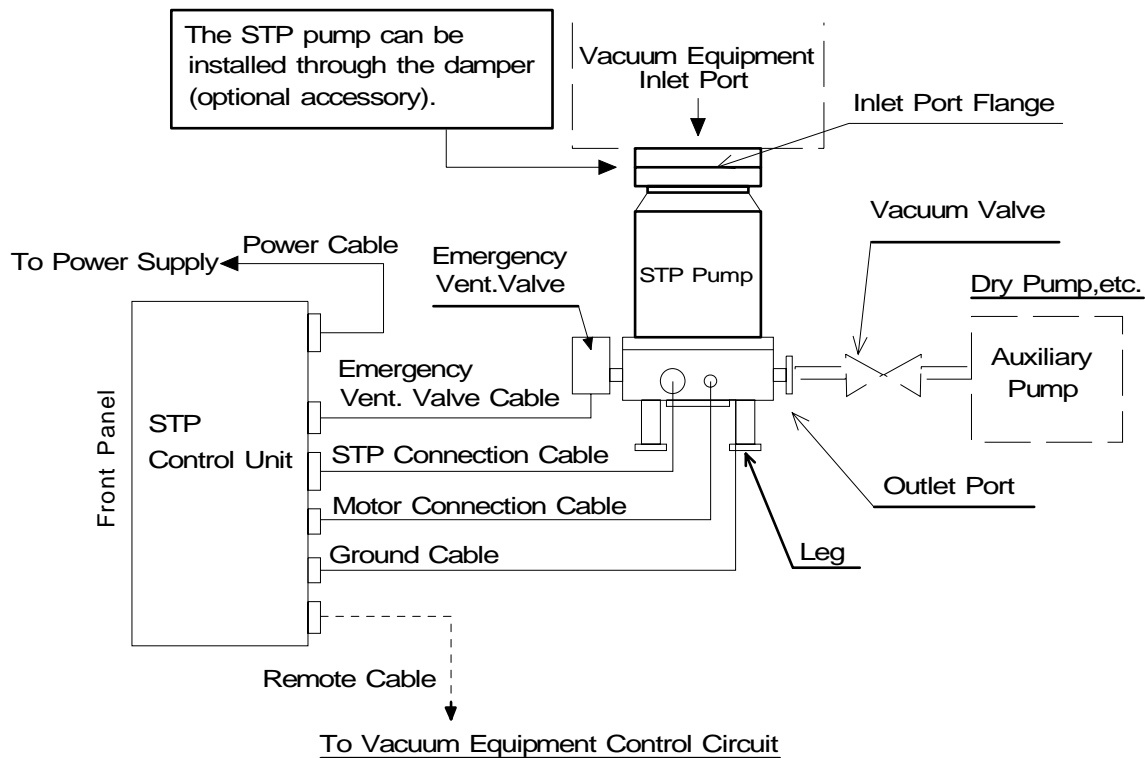

Figure 3.2 Installation of the STP Pump to the Vacuum Equipment

CAUTION

Chlorine or fluorine system gases can be used in chemical specific pumps (type C). When you use gases including alkaline metals, but excluding Li, gases including Ga, Hg, In, or Sn, or HBr, contact Seiko Instruments.

NEVER use corrosive gases (chlorine, fluorine, or other system gases) in the STP-H600/H1000 pump or other models without anti-corrosion treatment (see Section 1.1, "Usable Gases").

When you use the STP pump in a place subjected to exposure to radiation, contact Seiko Instruments.

DO NOT open the STP pump through the flange to atmospheric air while the STP pump is running.

If atmospheric air flows into the STP pump, it may not function normally.

Depending upon the type of the auxiliary pump used, atmospheric air may reverse flow into the STP pump when the auxiliary pump stops. Attach a vacuum valve to the middle of the piping between the STP pump outlet port flange and the auxiliary pump, and close the vacuum valve when the auxiliary pump stops.

NOTICE

The STP pump cannot be used with the outlet port open to atmospheric air. Always use the auxiliary pump (dry pump or similar one).

Use an auxiliary pump with a pumping speed of 240 L/min or more.

Depending upon the type of the auxiliary pump used, oil vapor may contaminate the inside of the STP pump. Some oil viscosity could cause a malfunction when there is a strong reverse flow of oil.

Take the following measures to ensure the correct flow of oil:

- Attach a vacuum valve to the middle of the piping between the STP pump outlet port flange and the auxiliary pump.
- Attach an absorption trap adjacent to the vacuum valve.

3.3.1 Cleaning the Seal

Inspect the seals of inlet and outlet port flanges for dirt or oil spots before installing the STP pump in the vacuum equipment.

Take the following measures for cleaning the seals:

- Clean off with a pure gas.
- Wipe with proper solvent (such as alcohol).

CAUTION

A splinter shield is attached to the inlet port flange to prevent foreign particles from falling into the STP pump.

Always leave the splinter shield attached during operation.

NOTICE

The splinter shield cannot perfectly prevent foreign materials from falling into the STP pump.

DO NOT install the STP pump in such a manner that foreign materials can easily fall into it (for example, Si wafers or samples are positioned above the STP pump). If installing the STP pump in such a manner, always attach a shield plate with sufficient conductance above the STP pump to prevent foreign materials from falling into it. Foreign materials falling into the STP pump through the splinter shield may result in product damage.

Be careful not to scratch the flange of the STP pump.

Check whether or not there are scratches on the surface, before installing the STP pump.

3.3.2 STP Pump Installation Positions

The STP pump can be installed vertically, horizontally, upside-down and slanted.

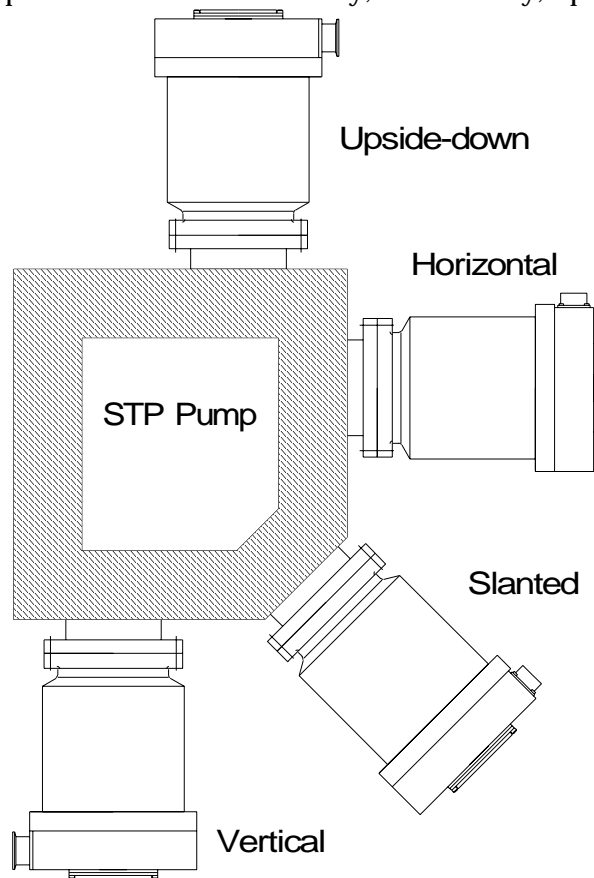

Figure 3.3 STP Pump Installation Positions

When installing the STP pump in a horizontal or slanted position, it is recommended to install it so that the direction of the outlet port is on a vertical or horizontal plane in the direction of the gravity. This makes it possible to reduce the load on the magnetic bearing and the heat generated by the STP pump.

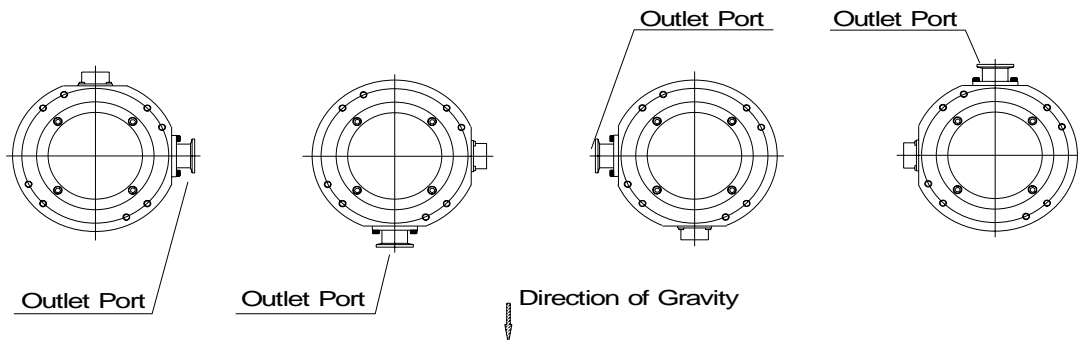

Figure 3.4 Positions of the Outlet Port on the Horizontally or Slanted Installed STP Pump

3.3.3 How to Secure the STP Pump



The STP pump is provided with a high-speed rotor. The worst-case failure may result in a jump in rotational torque leading to personal injury or peripheral equipment damage.

The method of securing the STP pump will depend on the installation requirements. Secure the STP pump to the vacuum equipment as follows:

Design and secure the mounting for the STP pump so that it can withstand the maximum rotational torque. Refer to Table 3.2 for torque in pump abnormality.

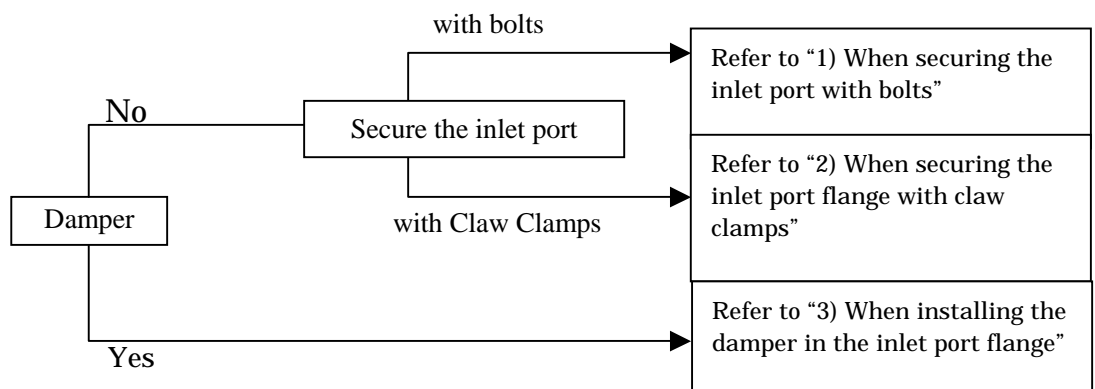

In some cases, the damper and the claw clamping cannot be used depend on the type of the STP pump.

Refer to Table 3.1 for tightening torque of the bolt.

Table 3.1 Tightening torque of bolt

Size of bolt	Tightening torque of bolt (Nm)
M8	12.0
M10	24.1
M12	42.1

When making the leg to secure the base, make them shortened more than ones attached to the STP pump.

Use a material that has a tensile strength of 600N/mm² or more.

When securing the base, use stainless steel securing bolts with a tensile strength class is 70 or more.



When using any securing method other than that specified in this manual, contact Seiko Instruments.

1) When securing the inlet port with bolts

Refer to Table 3.2 for torque in pump abnormality and recommended securing bolts. Secure the inlet port flange with all of the boltholes of the size specified in the Inlet Port Flange Standard.

Secure the base with all 8 screw-holes for legs or all 8 attached legs.

Follow “CAUTION” on page 3-8 about legs and bolts for securing the base.

Make sure that the recommended securing bolt may be different depending on the method of securing the base.

Table 3.2 Maximum Torque predicted and Recommended securing bolt for inlet port flange

Model of TMP		STP-H600					
Type of flange		VG150		ISO160F/ISO160		ICF203	
Torque in pump abnormality [Nm]		2.2×10 ⁴		2.2×10 ⁴		2.2×10 ⁴	
Base(8 positions)securing		No	Yes	No	Yes	No	Yes
Recommended securing bolt for TMP Flange	Type of bolt	Standard	Standard	Standard	Standard	Standard	Standard
	Type of steel*1	Carbon steel Alloyed steel	Stainless steel	Carbon steel Alloyed steel	Stainless steel	Carbon steel Alloyed steel	Stainless steel
	Strength*1	12.9 or more	70 or more	12.9 or more	70 or more	12.9 or more	70 or more

Model of TMP		STP-H1000					
Type of flange		VG200		ISO200F/ISO250F/ISO200		ICF253	
Torque in pump abnormality [Nm]		1.9×10 ⁴		1.9×10 ⁴		2.2×10 ⁴	
Base(8 positions)securing		No	Yes	No	Yes	No	Yes
Recommended securing bolt for TMP Flange	Type of bolt	Standard	Standard	Standard	Standard	Standard	Standard
	Type of steel*1	Stainless steel	Stainless steel	Stainless steel	Stainless steel	Stainless steel	Stainless steel
	Strength*1	70 or more	70 or more	70 or more	70 or more	70 or more	70 or more

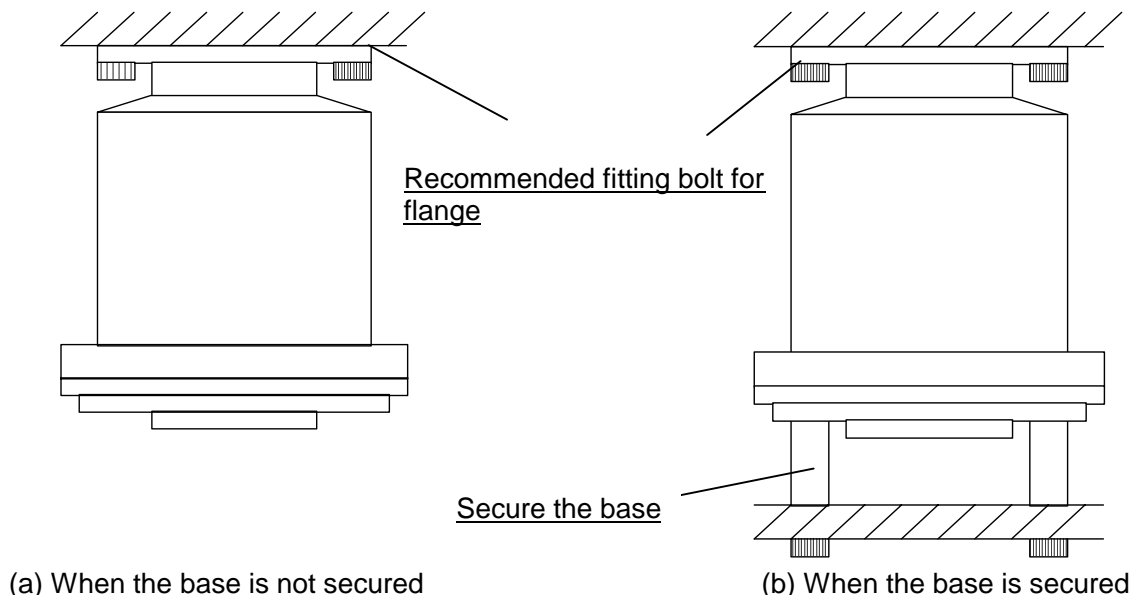

Figure 3.5 Example of securing the STP pump
(When securing the inlet port with bolts)

*1 Refer to ISO898-1(JISB1051), ISO3506(JISB1054) and AMS6119(Aerospace Material Specification)

2) When securing the inlet port flange with claw clamps

Refer to Table 3.2 for rotational torque.

When securing the inlet port flange with only the claw clamp, the vacuum equipment cannot withstand the maximum rotational torque generated by the worst-case failure. To make the vacuum equipment withstand abnormal torque, secure the base with all 8 screw-holes for legs or all 8 attached legs.

Follow “CAUTION” on page 3-8 about legs and bolts for securing the base.

For the claw clamp-type, use the required number of claw clamps as specified in Table 3.3. Position the claw clamps evenly on the circumference.

Table 3.3 Number of Claw Clamps by Size of Flange

Size of Flange	Number of Claw Clamps
ISO 160 or less	4 or more
ISO 200 to 250	6 or more
ISO 320 or more	8 or more

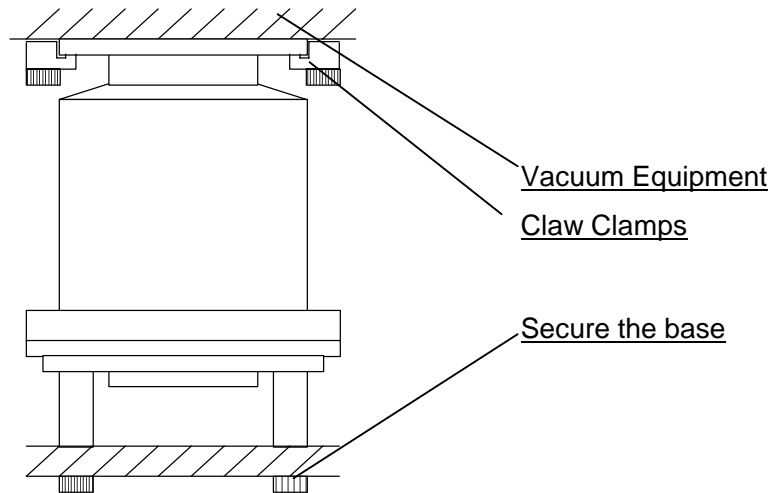

Figure 3.6 Example of securing the STP pump
(When securing the inlet port flange with claw clamps)

3) When installing the damper in the inlet port flange

Refer to Table 3.2 for rotational torque.

In case of using a damper, secure the base with all 8 screw-holes for legs or all 8 attached legs. Follow “CAUTION” on page 3-8 about legs and bolts for securing the base.

When the base cannot be secured because of the equipment design, install the pump with a torque restraint like the one shown in Figure 3.7 (b).



Use a damper only at the vertically upright position.

DO NOT remove the bolts and nuts attached to reinforce the damper.

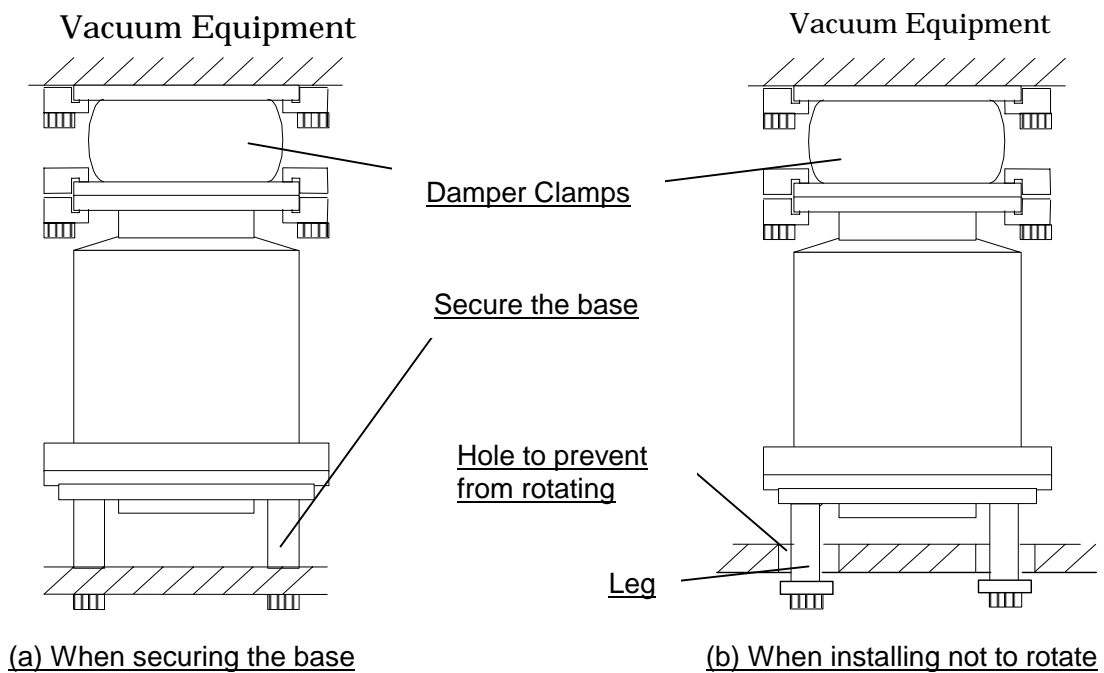

Figure 3.7 Example of securing the STP pump
(When installing the damper in the inlet port flange)

3.3.4 Vacuum Piping



DO NOT open the STP pump through the flange to atmospheric air while the STP pump is running.

If atmospheric air flows into the STP pump, it may not function normally.

Depending upon the type of the auxiliary pump used, atmospheric air may reverse flow into the STP pump when the auxiliary pump stops.

Attach a vacuum valve to the middle of the piping between the STP pump outlet port flange and the auxiliary pump, and close the vacuum valve when the auxiliary pump stops.

In order to let the STP pump bring its performance into full play, follow the precautions below:

- 1) Be careful not to scratch the flange of the STP pump.
Before installing the STP pump, check whether or not there are scratches on the surface.
- 2) Use steel or aluminum tubes with a low gas loss to connect the vacuum equipment to the STP pump.
- 3) Take measures for minimizing leakage. It is also necessary to degrease the tubes as regularly as possible to keep the gas loss as low as possible.
- 4) It is recommended to use an auxiliary pump of 240 L/min or more. However, the pressure at the inlet and outlet ports varies with the flow rate of gas, capacity of the vacuum equipment, length and material of the piping. Select an auxiliary pump in accordance with the capacity and starting method (simultaneous starting, starting after generating roughing vacuum) suitable for the vacuum equipment you use.
- 5) Connect the STP pump and the auxiliary pump using stainless steel or aluminum alloy tubing, flexible tubing, vacuum rubber or Teflon tubing, etc. The following measures can be used to avoid the transmission of the vibration of the auxiliary pump to the STP pump and the vacuum equipment.
 - DO NOT place the auxiliary pump on the same floor as the vacuum equipment.
 - Locate the auxiliary pump on a vibration-proof table.
 - Attain 1/3 or less of the rotational speed of the auxiliary pump, when adjusting the inherent frequency of the auxiliary pump installed on a vibration-proof table.
 - Attach a weight to the piping from the auxiliary pump, or secure the piping to a rigid, heavy object free of vibration.
 - Use a tube of high flexibility.
- 6) Depending upon the type of the auxiliary pump used, oil vapor may contaminate the inside of the STP pump. Some oil viscosity could cause a malfunction when there is a strong reverse flow of oil.
Take the following measures to ensure the correct flow of oil:
 - Attach a vacuum valve to the middle of the piping between the STP pump outlet port flange and the auxiliary pump.
 - Attach an absorption trap adjacent to the vacuum valve.

(1) Piping at the Inlet Port Flange

Attach the inlet port to the high vacuum side.

Maximum working pressure (Pressure at the inlet port flange applicable continuously)

- 67 Pa [0.5 Torr] (for water cooled)
- 5.3 Pa [4×10^{-2} Torr] (for air cooled)
- 0.9 Pa [7×10^{-3} Torr] (for natural air cooled)
- 13 Pa [0.1 Torr] (when TMS unit is used)

(2) Piping at the Outlet Port Flange

Attach the outlet port to the inlet port flange of the auxiliary pump (primary side pump).

Allowable backing pressure (Pressure at the outlet port flange applicable continuously)

- 400 Pa [3 Torr] (for water cooled, when TMS unit is used)
- 267 Pa [2 Torr] (for air cooled, natural air cooled)



NOTICE

To attain the ultimate pressure shown in Table 16.1, "Specifications for STP Pump", set the pressure at the outlet port flange to 1.3 Pa (10^{-2} Torr) or less.

3.3.5 Connecting the Emergency Vent. Valve

The emergency vent. valve stops the STP pump by introducing gases if any abnormality/error occurs in the STP pump.

Connect the emergency vent. valve (contained in the attached accessories) to the purge port as shown in Figure 3.7. Note that the side of the emergency vent. valve without filter is connected to the purge port.

Connect the cable for the emergency vent. valve to the connector, LEAK VALVE CON8A, of the STP control unit.



Always attach the emergency vent. valve.

DO NOT close the port of the emergency vent. valve (filter side) with a blank flange or other type of device.



The allowable gas pressure ranges from zero [atmospheric pressure] to 4.9×10^4 Pa [gauge pressure] (zero [atmospheric pressure] to 0.5 kgf/cm^2 [gauge pressure]).

Use a dry N₂ gas or other.

3.3.6 Connecting the Purge Port

When sucking reactive or corrosive gases, introduce a dry N₂ gas or other gas into the STP pump in order to protect the inside of the STP pump.

As shown in Figure 3.7, introduce a dry N₂ gas through the electromagnetic vent. valve, needle valve or similar valve (must be prepared by the customer) from the purge port.

For instructions on how to introduce the purge gas, See Section 7.1, "Gas Suction."



The proper amount of gas purge is approx. 3.4×10^{-2} Pa·m³/s (20 SCCM).

The allowable gas pressure ranges from zero [atmospheric pressure] to 4.9×10^4 Pa [gauge pressure] (zero [atmospheric pressure] to 0.5 kgf/cm^2 [gauge pressure]).

When not introducing the purge gas, close the purge port with the blank flange (attached at delivery).

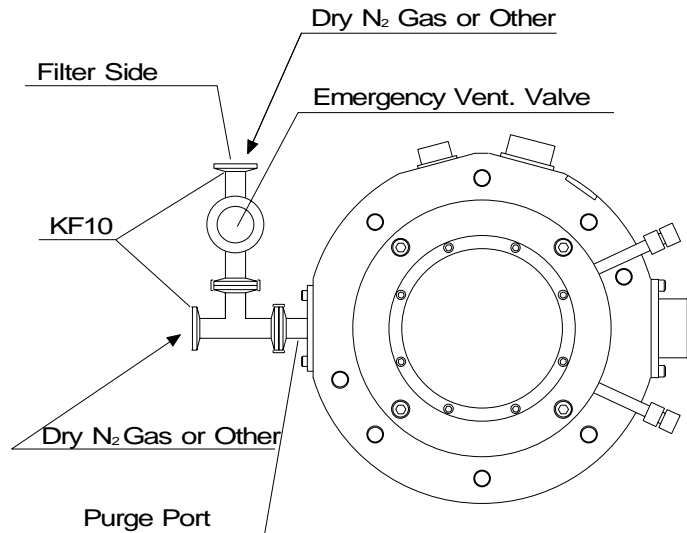

Figure 3.8 Connecting the Purge Port and Emergency Vent. Valve

3.3.7 Connecting the Ground Cable

Connect the ground cable (yellow/green) between the ground terminal of the STP pump and the ground terminal of the STP control unit.

When the resistance between the ground terminals is lower than 0.1 Ω , it is not necessary to connect the ground cable after installing the STP pump and the STP control unit.



When the resistance between the ground terminals is over 0.1 Ω , always connect the ground cable.

4 Installation of the STP Control Unit

4.1 Name and Function of Each Part

4.1.1 Front Panel

- (1) "POWER ON/OFF" Switch (illuminated alternate push button switch, green LED)
 - Press this switch to power ON/OFF the STP pump (MANUAL operation only).
 - The POWER ON/OFF built-in lamp lights when the power is ON.
- (2) "MOTOR START" Switch (momentary push button switch, black)
 - Press this switch with power ON to rotate and accelerate the STP pump (MANUAL operation only).
 - The "ACCELERATION" lamp lights simultaneously.
- (3) "MOTOR STOP" Switch (momentary push button switch, red)
 - Press this switch to decelerate and stop the STP pump (MANUAL operation only).
 - The "NORMAL OPERATION" lamp or the "ACCELERATION" lamp goes out and the "BRAKE" lamp lights simultaneously.
When the rotational speed is less than approx. 2000 rpm while the STP pump is accelerating, the "BRAKE" lamp does not light.
- (4) "HEATING ON/OFF" Switch (illuminated alternate push button switch, green LED)
 - Press this switch to control the power supplied to the baking (MANUAL operation only).
 - While the power is being supplied to the baking heater, the "HEATING ON/OFF" switch built-in lamp lights.
 - Functions only under the NORMAL OPERATION state (for details, see Section 8, "Remote Input/Output Signal Terminal Blocks").
- (5) "NORMAL OPERATION" Lamp (green LED)
 - Lights during rated operation (NORMAL OPERATION state).
- (6) "ACCELERATION" Lamp (green LED)
 - Lights during acceleration (ACCELERATION state).
- (7) "BRAKE" Lamp (yellow LED)
 - Lights during braking (BRAKE state).

- (8) "OVER TEMPERATURE" Lamp (red LED)
- Lights when any of the following abnormalities occurs:
 - a) When the motor or electromagnet overheats (110 or higher).
 - b) When the STP connection cable is not connected.
- (9) "BATTERY OPERATION" Lamp (red LED)
- Lights while the power is being supplied from the battery to the STP pump during a power failure.
- (10) "FAILURE" Lamp (red LED)
- Lights when any of the following abnormalities occurs:
 - a) When the inside of the STP control unit overheats (90 or more inside the heat sink).
 - b) When the motor or electromagnet overheats (110 or more).
 - c) When an abnormality occurs inside the inverter (overload, overspeed).
 - d) When the battery is thoroughly worn out and cannot be charged.
 - e) When the STP connection cable is not connected.
- (11) "EMERGENCY OPERATION" Lamp (red LED)
- Lights when any of the following abnormalities occurs:
 - a) When a power failure occurs.
 - b) When continuous vibration impact is applied to the rotor causing it to come into contact with the touch down bearing.
 - c) When the STP connection cable is not connected.

For details concerning lamps (8) to (11) and abnormalities, see Section 6, "Safety Functions When an Abnormality/Error Occurs" and Section 15, "Troubleshooting."

- (12) ROTATION Meter (tachometer)
- Indicates the rotational speed (rpm).
 - The needle moves to the black with an increase in rpm.
 - The needle moves to the red with a decrease in rpm.
 - The needle is located in the black during the rated operation.

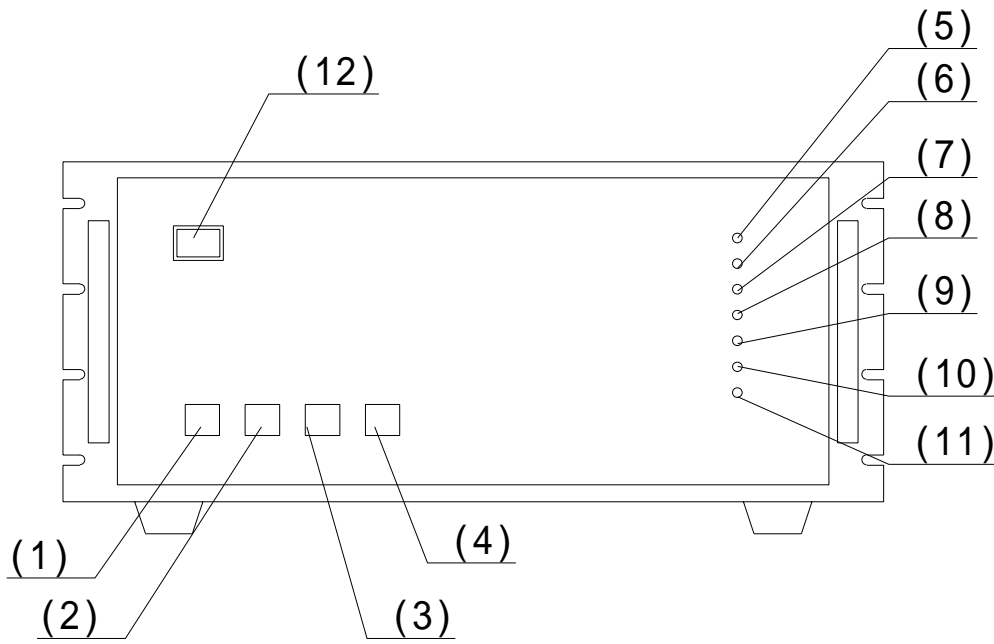



Figure 4.1 STP Control Unit Front Panel

4.1.2 Rear Panel



A hazardous live voltage may exist at connector/terminal that marked  . DO NOT touch the terminal. Doing so may result in electric shock. When operating connection/disconnection to terminal, always power OFF the STP pump (Switch the breaker "OFF").

- (13) AC POWER Terminal Block (TB1)
A maximum voltage : Equal to the input voltage of this terminal block. (MAX 240VAC)
 - For primary power input.
- (14) MAIN POWER Breaker
 - Switches ON/OFF the primary power.
 - A metal fitting is attached to secure the breaker at the OFF position.
- (15) P. CONNECTOR (CON5A)
A maximum voltage : 60VDC
 - For connection of the STP connection cable.
- (16) INVERTER OUTPUT Connector (CON2)
A maximum voltage : 55VDC
 - For connection of the motor connection cable.
- (17) LEAK VALVE Connector (CON8A)
A maximum voltage : 60VDC
 - For connection of the emergency vent. valve cable.
- (18) Ground Terminal
 - For connection of the ground cable between the STP pump and the STP control unit.
- (19) I/O TB2 Terminal Block
A maximum voltage : Equal to the input voltage of this terminal block. (MAX 250VAC)
 - For remote control.
- (20) DC I/O TB3 Terminal Block
A maximum voltage : 12VDC
 - For remote control.
- (21) START STOP TB5 Terminal Block
A maximum voltage : 12VDC
 - For remote control.

(22) START/STOP TB6 Terminal Block

A maximum voltage : Equal to the input voltage of this terminal block. (MAX 250VAC)

- For remote control.

For details concerning remote control terminal blocks (19) to (22), see Section 8, "Remote Input/Output Signal Terminal Blocks."

(23) "MANUAL/REMOTE" Changeover Switch

- When setting to MANUAL, only start, stop or other operations can be performed with the switches on the STP control front panel.
- When setting to REMOTE, only start, stop or other operations can be performed by inputting the remote signal.

(24) EXT. BATTERY (CON9) Connector

A maximum voltage : 55VDC

- For connection of an external battery.



When using EXT. BATTERY (CON9) connector, always disconnect the internal battery connector (see Section 10, "External Battery" for details).

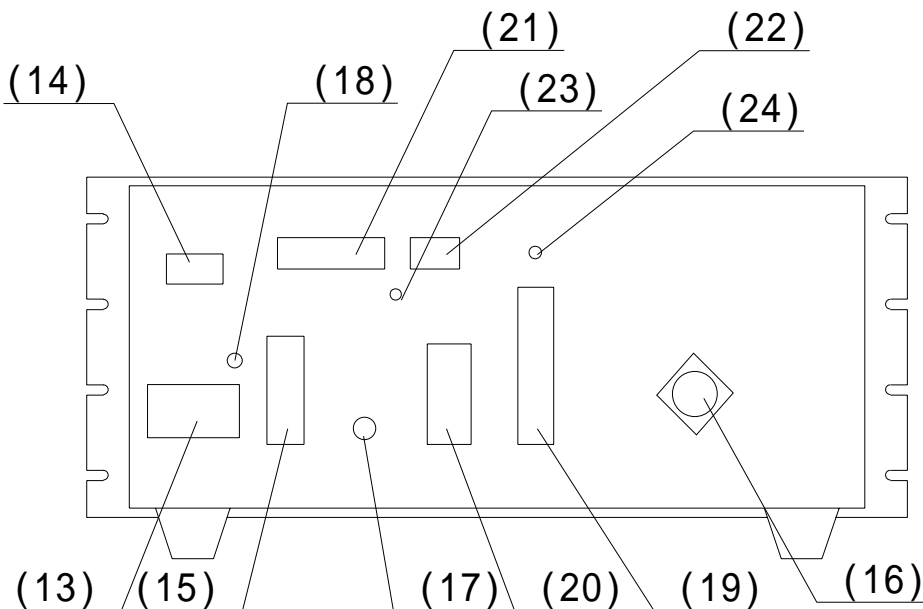

Figure 4.2 STP Control Unit Rear Panel

4.1.3 Inside of the STP Control Unit

- (25) Inverter
- This is a three-phase transistor-inverter which starts/stops the STP pump.
- (26) Fuses 3 to 9, 11, and 12
- These fuses protect as follows:
F3 and 4: 250 V, 5 A (for control power protection)
F5 to 7 : 250 V, 10 A, arc-extinguishing fuses
(for I/O TB2 terminal block power optional drive protection)
F8 and 9: 250 V, 10 A, arc-extinguishing fuses
(for internal and external batteries protection)
F11 and 12: 250 V, 0.1 A (for START/STOP TB6 terminal block protection)
- (27) Control Circuit Boards
- For control of the magnetic bearing, motor, safety functions, etc.
- (28) Internal Battery
- For backup during a power failure.
- (29) Internal Battery Connector
- For connection of internal battery (when using an internal battery, connect it to this connector).
 - The internal battery has been installed upon shipment of the STP control unit so that the customer can use it (the internal battery connector is connected to the internal battery).



When using an external battery, disconnect internal battery connector, then connect external battery connector (see Section 10, "External Battery" for details).

- (30) Air Cooling Fan
- For cooling the inside of the STP control unit.
- (31) "BATTERY NG" Lamp
- Lights when the battery capacity reduces to the minimum level (see Section 9.4, "BATTERY NG Lamp").
- (32) "Reset" Switch
- Resets the state of inability to start the STP control unit due to a decrease in the battery capacity (see Section 9.4, "BATTERY NG Lamp").

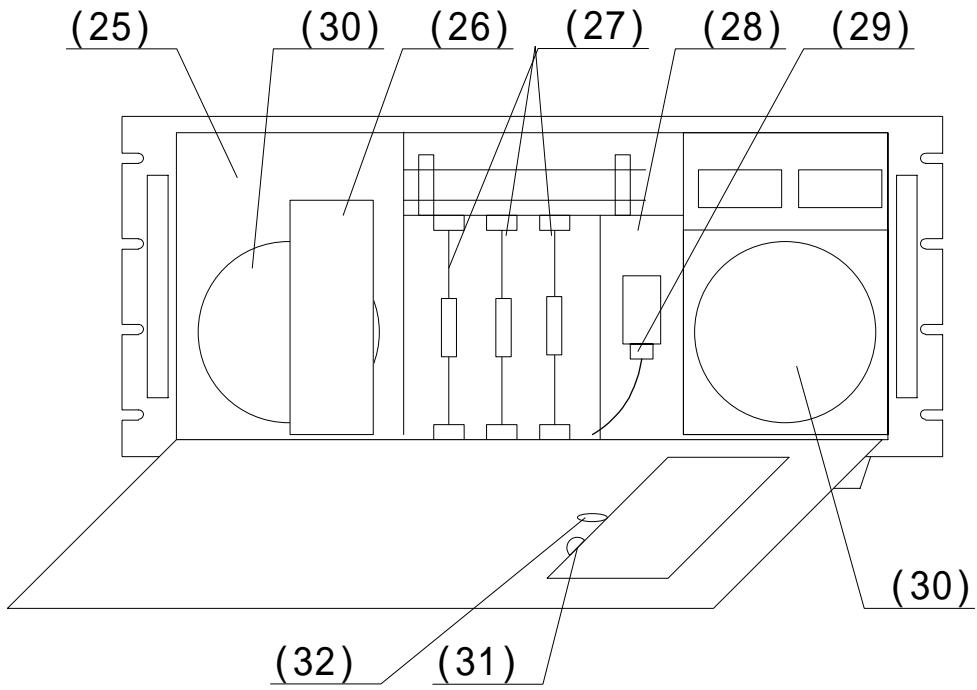

Figure 4.3 Inside of the STP Control Unit

4.2 Precautions Before Installation

4.2.1 Operating Environment

Install the STP control unit in a place meeting the following requirements:

Ambient Temperature	0 to 40
Ambient Relative Humidity	30 to 95% (no dew condensing)
Environment	<ul style="list-style-type: none"> ● A place free of exposure to direct sunlight. ● A place free of high humidity. ● A place free of dust. ● A place free of salty air. ● A place free of dripping water. ● A place free of explosive or inflammable gas. ● A place free of corrosive gas. ● A place free of radiation. ● A place free of strong magnetic and electric fields. ● A place free of excessive vibration. ● A place free of a source of electric noise.
Installation Condition	<ul style="list-style-type: none"> ● Install the STP control unit horizontally (within $\pm 10^\circ$).

4.2.2 Installation Area

Leave enough space for the following in addition to that for the STP control unit.

- Space for maintenance and inspection
- Space for inlet and outlet of air for cooling
 - Top and side: 5 cm or more
 - Bottom: 2.4 cm or more (height of the rubber foot)
- Space for connecting the cables
 - Rear: 15 cm or more



The minimum bending radius of the STP connection cable is 150 mm (see Figure 16.2, "External Appearance of the STP Control Unit" [Cable Space]). DO NOT excessively bend the cables and beware of any obstacles when installing the STP pump. Also, leave enough space to install other cables without bending them excessively.

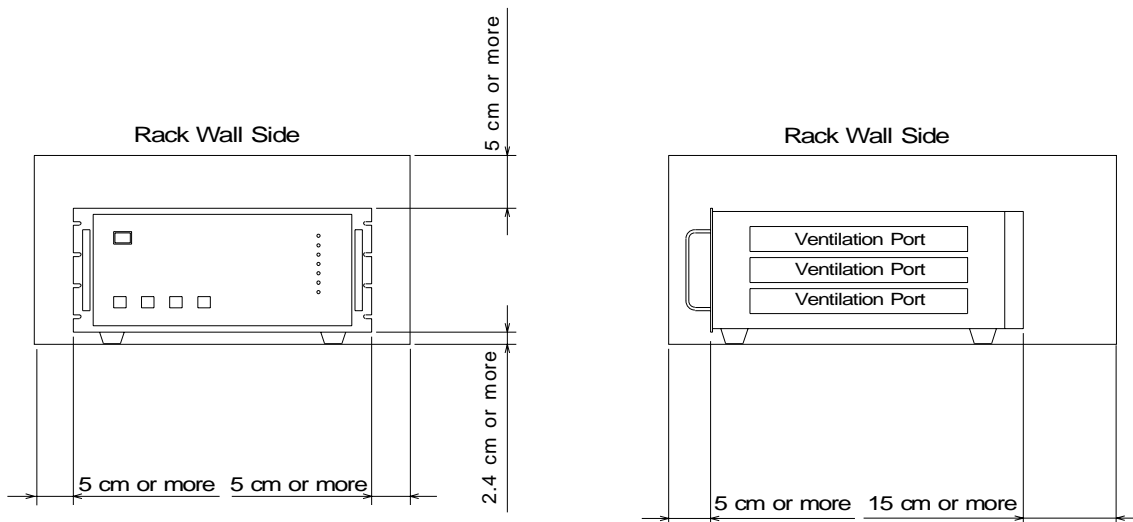

Figure 4.4 Peripheral Space of the STP Control Unit

4.3 Attaching the STP Control Unit Front Panel to a Rack

The dimensions of the STP control unit front panel conform to JIS. Therefore, this panel can be attached to any type of commercially-available racks.

Attach the front panel unit to the rack according to the following steps:

1) When attaching the front panel to a rack:

- Attach the front panel to a rack using the screw holes for the front panel.
- Also support the STP control unit from the bottom using a support angle or a similar tool.

2) When attaching the front panel to a movable rack:

- Attach the front panel to a movable rack using the screw holes for the front panel.
- To protect the STP control unit during transport, remove the rubber foot from the bottom and attach the STP control unit to the rack using the screw holes for the rubber foot.



The STP control unit cannot be supported with only the screws on the front panel (the STP control unit is a heavy product). Always support it from the bottom. DO NOT block the ventilation port.

For the peripheral space of the STP control unit, see Figure 4.4, "Peripheral Space of the STP Control Unit."



For the dimensions of the front panel and positions of screw holes for the rubber foot, see Figure 16.2, "External Appearance of the STP Control Unit."

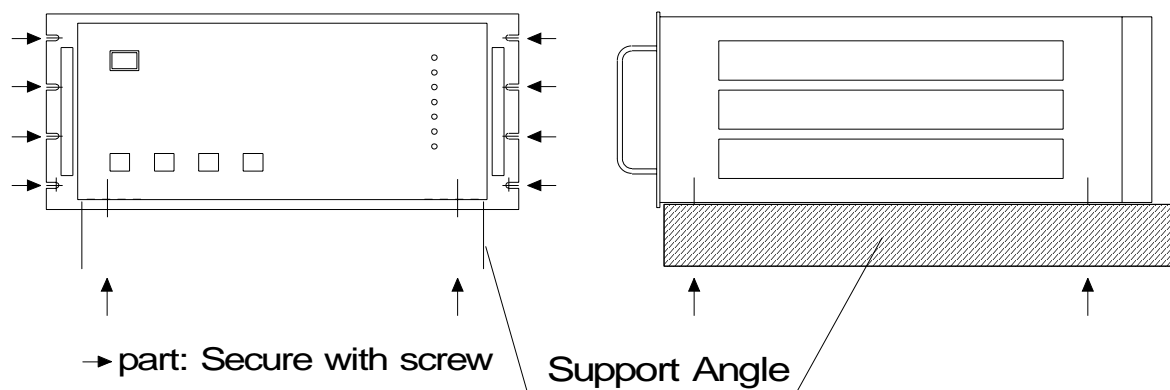

Figure 4.5 Example of Securing the STP Control Unit

4.4 Cable Connection

4.4.1 Name and Dimensions of Each Cable

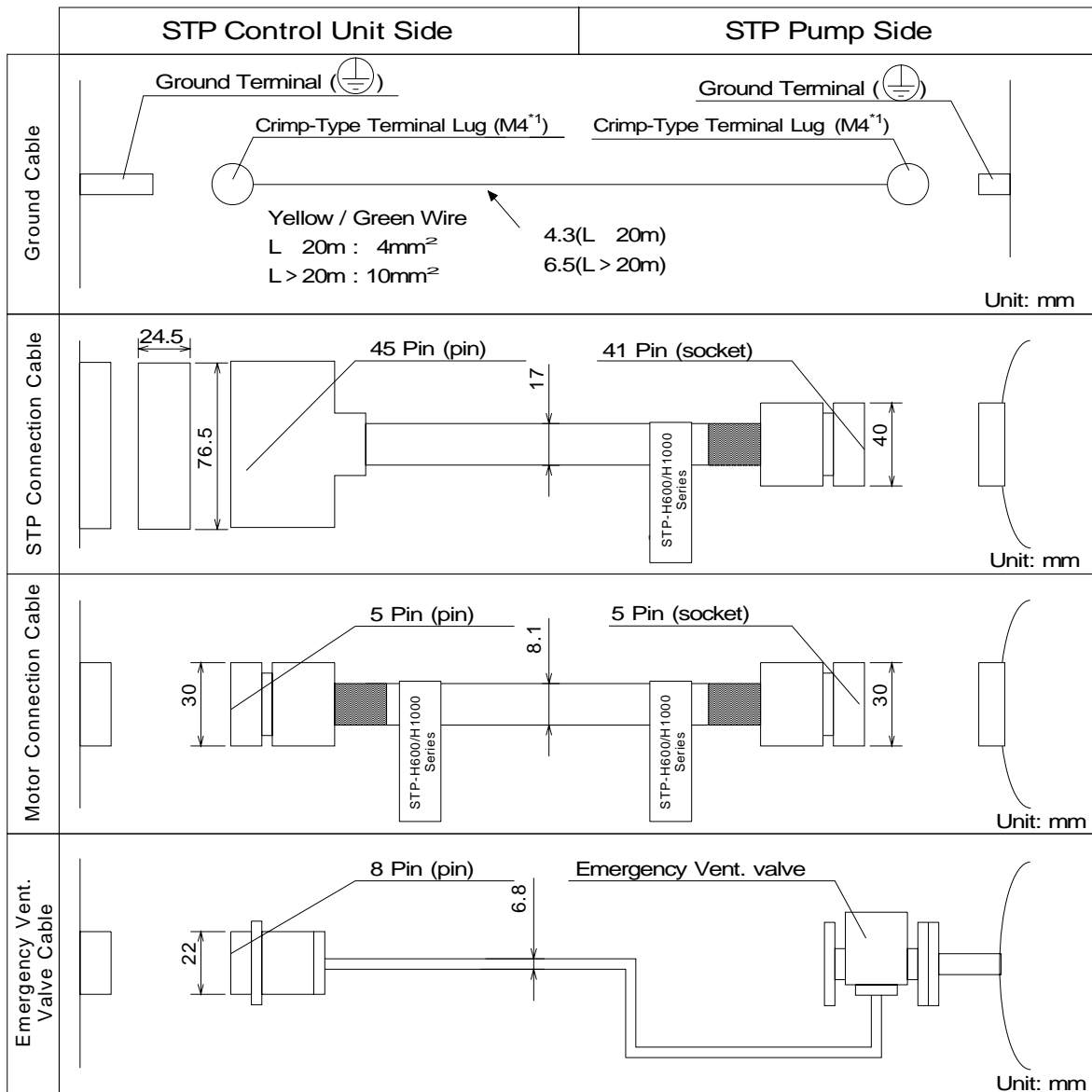
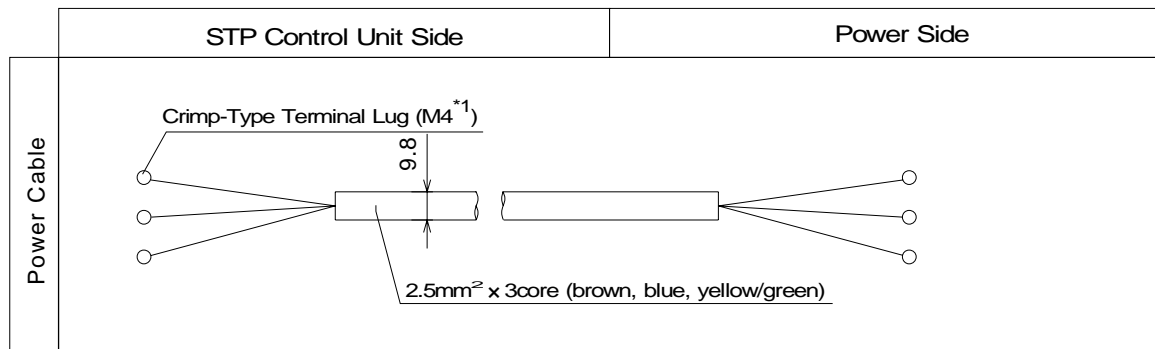
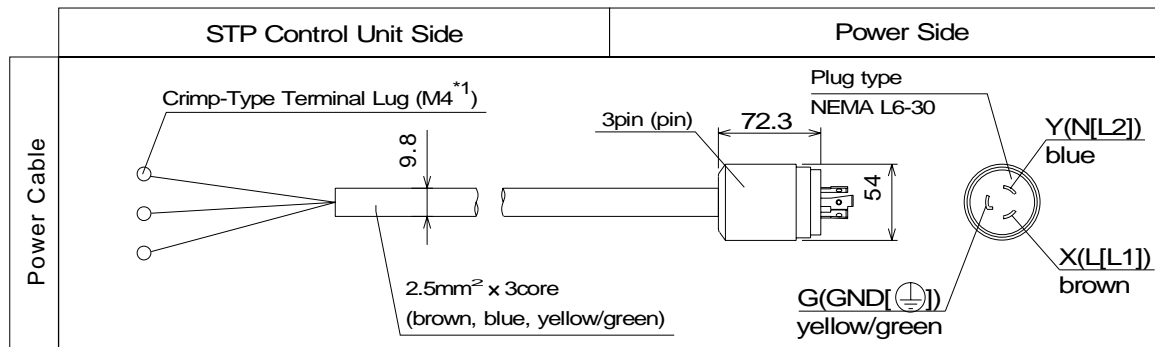

Figure 4.6 External Dimensions of Each Cable

*1: JIS



(a) without the Power Plug



(b) with the Power Plug²

Figure 4.7 External Dimensions of the Power Cable

¹: JIS

²: Recognized model to UL3101-1 standard has power cable with the plug.

4.4.2 How to Connect the Cables



When connecting/disconnecting cables, always power OFF the STP pump (switch the breaker "OFF").

Failure to do so may result in electric shock or product damage.

With each connector, align the position of the guide key and insert the pin vertically so as not to bend it.

If the pin is bent, not only may the connector not function normally, but may the pin make contact, resulting in a malfunction.

Lock and securely tighten each connector and screw.

DO NOT apply voltage to each pin and DO NOT cause any short-circuiting between pins.

Connect each cable securely. DO NOT place heavy objects on the cables nor bend them excessively.

Support each cable so as not to apply direct force to the connectors or terminals. If any problem occurs in cables, connectors or terminals, the STP pump may not function normally.

1) **Connecting Ground Cable**

Connect the ground cable (yellow/green) between the ground terminal of the STP pump and the ground terminal of the STP control unit.

When the resistance between the ground terminals is lower than 0.1 Ω , it is not necessary to connect the ground cable after installing the STP pump and the STP control unit.



First, connect the ground cable. Next, connect other cables.

When the resistance between the ground terminals is over 0.1 Ω , always connect the ground cable. Failure to do so may result in electric shock.

2) Connecting the STP Connection Cable

Connect the socket side of the STP connection cable to the STP connector of the STP pump and connect the pin side to "P.CONNNECTOR CON5A" of the STP control unit.



Always use the STP pump, STP control unit and the STP connection cables of the same model name, serial number and cable length. Failure to do so may result in product damage.

Contact your nearest Seiko Seiki representative if you plan to use units with the same model name but different serial numbers and cable length; They must be adjusted. In some cases, the configuration may need more adjustment.

Use the STP connection cable that has a label affixed

STP-H600/H1000
Series

The use of different cables may result in product damage.

3) Connecting the Motor Connection Cable

Connect the socket side of the motor connection cable to the motor connector of the STP pump and connect the pin side to "INVERTER OUTPUT CON2" of the STP control unit.



Use the motor connection cable that has a label affixed

STP-H600/H1000
Series

The use of different cables may result in product damage.

4) Connecting the Emergency Vent. Valve Cable

Connect the emergency vent. valve to the purge port of the STP pump and the connector to "LEAK VALVE CON8A" of the STP control unit (see Section 3.3.5, "Connecting the Emergency Vent. Valve").

- 5) **Connecting Primary Power (Primary Side) Cable**
 Connect power cable to the "AC POWER TB1" on the STP control unit rear panel as shown in Table 4.1.

Table 4.1 Connecting Primary Power Cable

TB1 Pin No.	Cable Color	Remarks
1 [L(L1)]	Brown	Single phase 200 to 240 V AC ±10% 13A (maximum) Both 50/60 Hz
2 [N(L2)]	Blue	
3 [PE()]	Yellow/Green	Ground

Secure primary power cable to the STP control unit rear panel using the cable fitting tool (see Figure 4.7).



- Connect the primary power cable securely to prevent incorrect wiring.
- DO NOT apply surge voltage exceeding 1 kV to the input power line.
- Always ground primary power cable to prevent electric shock.
- DO NOT remove the ground cable attached to the terminal block cover.

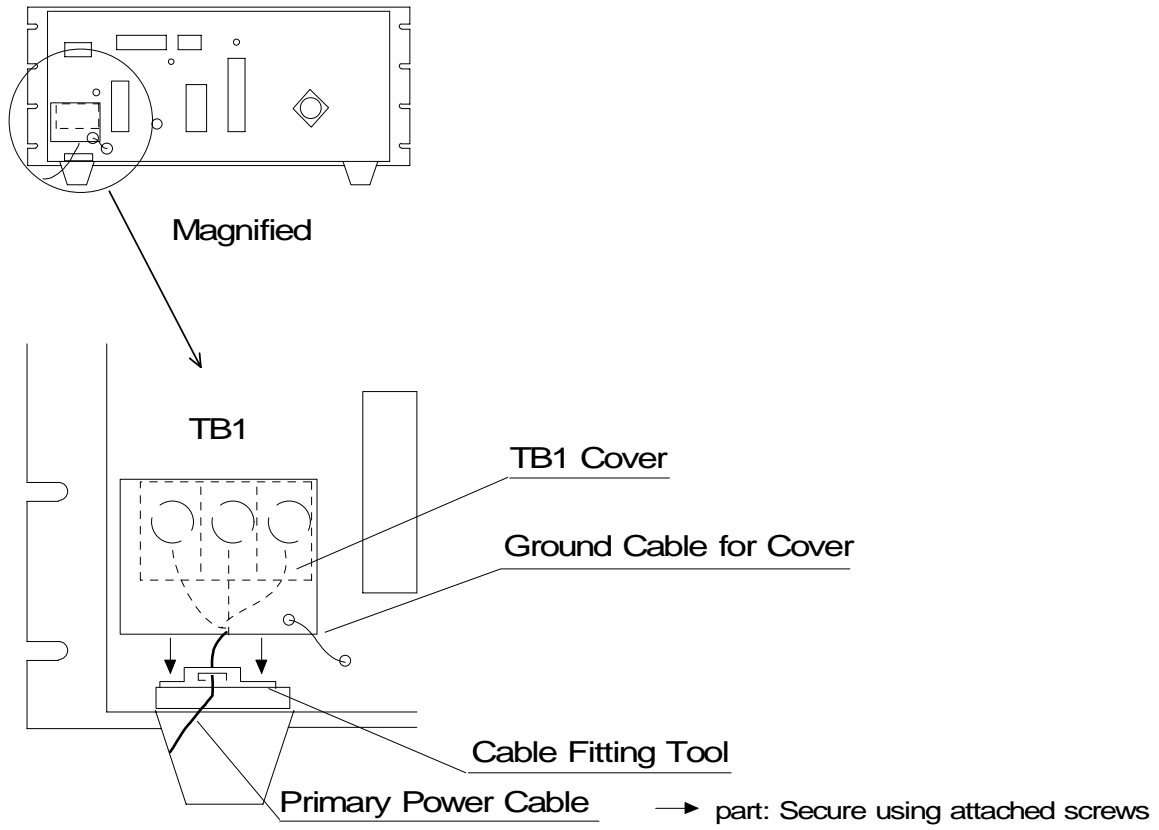

Figure 4.8 How to Secure Primary Power Cable

5 How to Start/Stop the STP Pump



NEVER connect or disconnect any cables while the power is ON.

NEVER turn the primary power OFF (switch the breaker "OFF") while the STP pump is in rotation.

DO NOT release the inlet port flange or outlet port flange into the atmosphere while the STP pump is in rotation.

5.1 Before Starting

After completing installation, piping, leakage test of the STP pump and installation of the STP control unit, the STP pump is ready for start.

Check the following items before starting:

- 1) Are the STP pump and the STP control unit secured according to the appropriate method?
- 2) Is the primary power cable connected correctly to the power supply?
- 3) Is the power voltage selected properly?
- 4) Do the manufacturing No. and the cable length of the STP pump, the STP control unit and the STP connection cable match?
- 5) Are the labels affixed correctly to the STP connection cable and the motor connection cable?

STP-H600/H1000
Series

- 6) Are the ground cable, the STP connection cable, the motor connection cable, and the emergency vent. valve cable securely connected?
Is the connection cable securely connected?
Are each terminal and each connector securely locked?

5.2 Starting/Stopping Time

Starting time: Approx. 6 minutes after start operation.

Stopping time: Approx. 6 minutes after stop operation.

If the rotational speed does not attain the rated speed within about 15 minutes, the "FAILURE" lamp lights. Before restarting the STP pump, always check whether or not there is leakage from the piping or the vacuum equipment and also confirm the capacity and the START state of the auxiliary pump.



When start/stop operations are frequently performed, the STP pump may overheat. Avoid doing so.

5.3 Start Procedures

Start the auxiliary pump before or simultaneously with start of the STP pump.
Open the vacuum valve located at the outlet port flange side after starting the auxiliary pump.



DO NOT open the vacuum valve without operating the auxiliary pump.
Doing so may cause a reverse flow of oil, which could contaminate the inside of the STP pump.

5.4 Stop Procedures

Close the vacuum valve located at the outlet port flange side just before or after stopping the STP pump.
After closing the valve, stop the auxiliary pump.



DO NOT stop the auxiliary pump without closing the vacuum valve. Depending upon the type of the auxiliary pump, doing so could cause a reverse flow of atmospheric air into the STP pump, which may result in a malfunction.



DO NOT stop the auxiliary pump without closing the valve.
Doing so may cause a reverse flow of oil, which could contaminate the inside of the STP pump.

There are two methods of operating the STP pump: MANUAL and REMOTE.

Select one which fits your vacuum equipment.

5.5 Manual Operation

Slide the "MANUAL/REMOTE" changeover switch on the rear panel to "MANUAL."

5.5.1 Powering ON

- 1) Switch ON the breaker on the rear panel (to prevent incorrect operation, a metal fitting is attached to the breaker. Loosen the screw, lift the metal fitting and secure it).
- 2) Press the "POWER ON/OFF" switch (the switch is thoroughly locked down). The magnetic bearing functions and the rotor levitates (POWER ON state). The "POWER ON/OFF" switch built-in lamp lights.

5.5.2 Starting the STP Pump

- 1) Press the "MOTOR START" switch on the front panel after powering ON to start and accelerate the STP pump. The "ACCELERATION" lamp lights (ACCELERATION state).
- 2) When the STP pump attains the rated speed of rotations, the "ACCELERATION" lamp goes out, and the "NORMAL OPERATION" lamp lights (NORMAL OPERATION state).

5.5.3 Stopping the STP Pump

- 1) Press the "MOTOR STOP" switch on the front panel to stop the STP pump. The STP pump starts to decelerate and stop. The "NORMAL OPERATION" lamp or the "ACCELERATION" lamp goes out, and the "BRAKE" lamp lights (BRAKE state) (when the rotational speed is less than approx. 2000 rpm while the STP pump is accelerating, the "BRAKE" lamp does not light).
- 2) The "BRAKE" lamp goes out when the rotational speed slows down to approx. 1000 rpm.

5.5.4 Starting the STP Pump after Stopping

Press the "MOTOR START" switch on the front panel to reaccelerate the STP pump.

5.5.5 Powering OFF

- 1) When all of the "ACCELERATION," "NORMAL OPERATION" and "BRAKE" lamps are off:
Press the "POWER ON/OFF" switch. The switch pops up into the unlocked position, the magnetic bearing stops, and the rotor lands (POWER OFF state). The "POWER ON/OFF" switch built-in lamp goes out.

- 2) When one of the "ACCELERATION," "NORMAL OPERATION" and "BRAKE" lamps is lit:
 - i. Even when the "POWER ON/OFF" switch is OFF, the rotor will not land. Also, operation of the STP pump remains unchanged. The "POWER ON/OFF" switch built-in lamp remains lit.
 - ii. When the STP pump stops under the above state, the magnetic bearing stops, and the rotor automatically lands at the time the "BRAKE" lamp goes out.

NOTICE

The brake of the STP pump disengages at approx. 1000 rpm and the "BRAKE" lamp goes out. The STP pump rotates by inertia even after the "BRAKE" lamp has gone out.

Powering OFF immediately after the "BRAKE" lamp goes out or while any lamp of the "ACCELERATION," "NORMAL OPERATION," or "BRAKE" lamp is being lit causes the touch down bearing to touch the rotor resulting in a noise.

Frequent POWER OFF operations will expedite the wear of the touch down bearing. It is recommended to power OFF the STP pump after it stops thoroughly.

5.6 Remote Operation

Slide the "MANUAL/REMOTE" changeover switch on the STP control unit rear panel to "REMOTE."

5.6.1 Powering ON

Switch ON the breaker on the STP control unit rear panel, (to prevent incorrect operation, a metal fitting is attached to the breaker. Loosen the screw, lift the metal fitting and secure it).
 The magnetic bearing functions and the rotor levitates (POWER ON state).
 The "POWER ON/OFF" switch built-in lamp lights.

5.6.2 Starting/Stopping the STP Pump

There are three methods of starting/stopping the STP pump. Use one of them.

Table 5.1 Starting/Stopping the STP Pump During Remote Operation

Method	Terminal Block	Starting the Pump	Stopping the Pump
1	TB5	1) Short the circuit between (3) - (2) (STOP IN). 2) Short the circuit between (2) - (1) (START IN) for 0.3 seconds or more. However, when inputting the signal simultaneously with switching ON the breaker on the rear panel, continue to short the circuit for 5 seconds or more.	Open the circuit between (3) - (2) (STOP IN).
2	TB5	Short the circuit between (1) - (3) (START/STOP IN).	Open the circuit between (3) - (1) (START/STOP IN).
3	TB6	Input 25 to 250 V AC or 24 to 48 V DC between (2) - (1) (START/STOP IN). With DC, the (+) side can be connected to either (2) or (1).	Open the circuit between (2) - (1) (START/STOP IN).

5.6.3 Starting the STP Pump After Stopping

Perform the rotation procedures to reaccelerate the STP pump. See Section 5.6.2, "Starting/Stopping the STP Pump."
 The STP pump can be reaccelerated even while the STP pump is stopping.

5.6.4 Powering OFF

When all three ("ACCELERATION", "NORMAL OPERATION" and "BRAKE") lamps are off, switch the breaker OFF on the rear panel.

The magnetic bearing stops, and the rotor lands.

The POWER ON/OFF switch built-in lamp goes out.



NEVER switch OFF the breaker on the rear panel while any of the "ACCELERATION," "NORMAL OPERATION" and "BRAKE" lamps is being lit. If doing so under the above condition, the STP pump may react as if there was a power failure.



The brake of the STP pump disengages at approx. 1000 rpm and the "BRAKE" lamp goes out. The STP pump rotates by inertia even after the "BRAKE" lamp has gone out.

Powering OFF immediately after the "BRAKE" lamp goes out causes the touch down bearing to touch the rotor resulting in a noise.

Frequent POWER OFF operations may expedite the wear of the touch down bearing. It is recommended to power OFF the STP pump after it stops thoroughly.

6 Safety Functions When an Abnormality/Error Occurs

The STP pump is provided with safety functions for various abnormalities/errors (See Tables 6.3 and 6.4, "Safety Functions").

For troubleshooting, see Section 6.2, "Restarting After Any Safely Function Operates" and Section 15, "Troubleshooting."

6.1 Safety Functions

6.1.1 Power Failure

<Operation at a Power Failure>

When power voltage drops below 170 V due to a power failure, internal battery of the STP control unit automatically activate to supply power to the STP pump in order to maintain normal function of the magnetic bearing (backup operation during a power failure).

- 1) The STP control unit detects any power failure of 2 seconds or more and automatically switches to the BATTERY OPERATION mode and the STP pump decelerates. Gases are introduced from the emergency vent. valve at approx. 7000 rpm and the rotor lands on the touch down bearing and stops at approx. 2000 rpm.

In the BATTERY OPERATION mode, the "BATTERY OPERATION" lamp and the "EMERGENCY OPERATION" lamp light, and an alarm signal is output from I/O TB2 ALARM OUT terminals (10) – (9), (10) – (11) regardless of MANUAL or REMOTE OPERATION mode.

When the rotor lands on the touch down bearing, the "BATTERY OPERATION" lamp and the "EMERGENCY OPERATION" lamp go out, and the alarm output is reset.

- 2) In case of a power failure of less than 2 seconds, the STP control unit does not detect it and the STP pump continues rotating.

<Operation after a Power Recovery>

- 1) **MANUAL Operation**
The STP pump continues decelerating even after a power recovery. Press the "START" switch to reaccelerate the STP pump.
- 2) **REMOTE Operation**
 - When the START signal is input to the REMOTE input terminal at a power recovery to reaccelerate the STP pump.
 - When the START signal is not input to the REMOTE input terminal after the power recovery, the STP pump continues the BRAKE operation.



Establish a sequence so that power can be supplied to the STP control unit immediately after a power recovery.

Table 6.1 shows the states of lamps and the REMOTE output signal at a power failure.

Also, Table 6.2 shows operations of the STP pump after a power recovery.

Table 6.1 State of Lamps and REMOTE Output Signal at Power Failure

Power failure time	Rotational speed (rpm)	LED lamps	REMOTE output signal (I/O TB2)	
		"BATTERY OPERATION" "EMERGENCY OPERATION"	Power ON signal	ALARM signal
Approx. 2 sec. or more	Less than 2000 2000 or less	Lights Goes out	ON OFF	ON OFF
Less than approx. 2 sec.	Does not detect power failure.			

Table 6.2 Operation of the STP Pump after Power Recovery

Power failure time	MANUAL operation	REMOTE operation	
	STP pump operation after power recovery	"START" REMOTE signal input after power recovery	STP pump operation after power recovery
Approx. 2 sec. or more	Deceleration/Stop	Yes	Reacceleration
		No	Deceleration/Stop
Less than approx. 2 sec.	Continues as before.		

6.1.2 Abnormal State of Magnetic Bearing

When the magnetic bearing does not function normally due to a breakage of the STP connection cable, disconnection of connectors or any abnormality/error of the STP control circuit, the rotor falls on the touch down bearing. Simultaneously, the emergency vent. valve is opened to introduce gases and the STP pump stops, and the "EMERGENCY OPERATION" lamp lights.



When an abnormality/error occurs in the magnetic bearing, check the STP pump as well as the STP control unit, and contact Seiko Seiki.

6.1.3 Excessive Vibration

When serious vibration or mechanical shock causes the rotor to touch the touch down bearing (due to external vibration/impact, intrusion of atmosphere or foreign materials into the STP pump or rotor imbalance), the emergency vent. valve is opened to introduce gases, the STP pump stops, and the "EMERGENCY OPERATION" lamp lights.

6.1.4 Inverter Overload

When the STP pump does not attain the rated speed within about 15 minutes after starting or when the ACCELERATION state remains unchanged during operation for about 15 minutes, the inverter stops and the STP pump continues rotating by inertia. The "FAILURE" lamp lights.

6.1.5 Overheating Inside the STP pump

When the temperature of the motor inside the STP pump exceeds 110 °C due to an abnormal baking temperature or overload operation, the STP pump enters the STOP operation. The "OVER TEMPERATURE" lamp and the "FAILURE" lamp light.

6.1.6 Overheating Inside the STP Control Unit

When the temperature inside the STP control unit (at the heat sink) exceeds 90 °C due to a failure in the air cooling fan, external heat source, etc., the STP pump enters the STOP operation. The "FAILURE" lamp lights.

6.1.7 Overspeed

When the rotational speed of the STP pump exceeds 37,500 rpm due to a failure in the inverter, the STP pump enters the STOP operation. The "FAILURE" lamp lights.

6.1.8 Abnormal Battery Voltage

When battery capacity became less than operating limit value or there was connection mistake, there may be the thing that battery abnormality is detected. When battery abnormality was detected, the STP pump does not operate even if the STP pump START operation is performed.

The "FAILURE" lamp lights

(Both the "EMERGENCY OPERATION" lamp and the "BATTERY NG" lamp inside the STP control unit front panel may light).

When battery voltage became less than DC21V, battery abnormal detection operates.

However, when capacity of battery is less than operating limit value largely, there may be the thing that battery abnormal detection does not operate.



NEVER disconnect the internal or external battery connection cable while the STP pump is under POWER ON state.



When the "BATTERY NG" lamp inside the STP pump front panel comes on, "FAILURE" and "EMERGENCY OPERATION" lamps also come on.

When the power is turned on again, the "FAILURE" lamp goes out, while the "BATTERY NG" and "EMERGENCY OPERATION" lamps still remain lit.

6.1.9 Failure of Brake

If the brake is broken, the emergency vent. valve is opened to force the STP pump to stop.

6.2 Restarting after Any Safety Function Operates

- 1) In case of a power failure:
Establish a sequence so that power can be supplied to the STP control unit immediately after a power recovery.
- 2) In case the "FAILURE" lamp lights due to an overload of the inverter (the STP pump continues rotating by inertia: [FREE RUN state]):

<MANUAL OPERATION>

- (1) Press the "MOTOR STOP" switch. The "FAILURE" lamp goes out and the FREE RUN state is reset.
- (2) Press the "MOTOR START" switch and press the "MOTOR STOP" switch again. The brake functions and the STP pump decelerates.
- (3) After the STP pump stops thoroughly (the "BRAKE" lamp goes out: the needle of the tachometer is in the red), turn "OFF" the "POWER ON/OFF" switch, switch the breaker "OFF," and remove probable causes of the abnormality/error.
- (4) Restart the STP pump and check if it operates correctly.

<REMOTE OPERATION>

- (1) Slide the "MANUAL/REMOTE" changeover switch on the rear panel to "MANUAL."
- (2) Press the "MOTOR STOP" switch. The "FAILURE" lamp goes out and the FREE RUN state is reset.
- (3) Press the "MOTOR START" switch and press the "MOTOR STOP" switch again. The brake functions and the STP pump decelerates.
- (4) After the STP pump stops thoroughly (the "BRAKE" lamp goes out: the needle of the tachometer is in the red) , switch the breaker "OFF," and remove probable causes of the abnormality/error.
- (5) Restart the STP pump and check if it operates correctly.

<In case the FREE RUN state is not reset after troubleshooting:>

- (1) Check the tachometer on the front panel.
- (2) If the needle is in the red, it means the STP pump has stopped.
Power OFF and switch the breaker "OFF."
- (3) If the needle is in the black, the STP pump is rotating.
Wait for it to enter the red. Then, power OFF and switch the breaker "OFF."
- (4) Restart the STP pump and check if operates correctly.



DO NOT power OFF and switch the breaker OFF until the needle is in the red.



If the FREE RUN state cannot be reset, it takes about 8 to 10 hours to stop the STP pump (the needle is in the red) because it rotates by inertia.
To stop the STP pump quickly, close the vacuum valve at the outlet port flange and introduce gas from the purge port into the STP pump.

3) Other Cases

After the STP pump stops thoroughly, power OFF, switch the breaker "OFF" and remove the cause of the abnormality/error. Then, restart the STP pump and check if it operates correctly.



For probable causes and troubleshooting, See Section 15, "Troubleshooting."

6.3 Operation of the Emergency Vent. Valve

The emergency vent. valve is opened immediately after an abnormality/error in the magnetic bearing, excessive vibration or any other abnormality/error is found. Gases (dry N₂ gases or other) are introduced through the emergency vent. valve into the STP pump.

Attach the emergency vent. valve taking care of the following NOTICE:



It is recommended to introduce dry N₂ gases to prevent the STP pump and vacuum equipment from getting contaminated.

The allowable gas pressure ranges from zero [atmospheric pressure] to 4.9x10⁴Pa [gauge pressure] (zero [atmospheric pressure] to 0.5kgf/cm² [gauge pressure]).

The rotor comes into contact with the touch down bearing, with the emergency vent. valve opened. This may damage the rotor or the touch down bearing. To stop the STP pump in a very short time, design an appropriate vacuum exhaust system that closes the vacuum valve at the outlet port flange when the emergency vent. valve is opened.

This prevents the rotor and the touch down bearing from being damaged.

The state of the emergency vent. valve can be checked using "DC I/O TB3 L. VALVE N. O. OUT Terminal (9)-(10)."

Table 6.3 Safety Functions

[E.V. used herein is the abbreviation for Emergency Vent.]

Abnormality /Error	Operation state of safety functions	Lamp indication	REMOTE output signal	State of the STP pump	Probable causes of an abnormality/error
Power failure	Failure time: 2 seconds or more (for details, refer to <u>Section 6.1.1, "Power Failure"</u>).	"BATTERY OPERATION" "EMERGENCY OPERATION"	"ALARM" "E.V. valve OPEN signal"	Levitation continues by battery. The STP pump stops. The E.V. valve functions at approx. 7000 rpm. The rotor lands on the touch down bearing at approx. 2000 rpm.	Power failure. Power cable breakage. Power cable disconnection
Abnormal magnetic bearing	Rotor descends onto the touch down bearing.	"EMERGENCY OPERATION"	"ALARM" "E.V. valve OPEN signal"	The E.V. valve is opened. The STP pump stops.	STP connection cable breakage. STP connection cable disconnection. Abnormal control circuit.
Excessive vibration	Rotor vibration: 100 μm p-p or more.	"EMERGENCY OPERATION"	"ALARM" "E.V. valve OPEN signal"	The E.V. valve is opened. The STP pump stops.	External vibration, and impact. Intrusion of atmospheric air. Intrusion of foreign materials.
Overload of inverter	Current of more than 40A flows into the inverter momentarily or current of more than 11.5A flows into the inverter continuously for 15 minutes.	"FAILURE"	"ALARM"	The inverter stops. The STP pump continues to rotate by inertia.	Leakage from the vacuum equipment or piping. Insufficient pressure at inlet and outlet port sides. Failure of starting of the auxiliary pump.

Abnormality /Error	Operation state of safety functions	Lamp indication	REMOTE output signal	State of the STP pump	Probable causes of an abnormality/error
Overheating inside the STP pump	Temperature of the STP pump motor: 110 or more	"OVER TEMPERATURE" "FAILURE"	"ALARM"	The STP pump stops.	Abnormal baking temperature. Insufficient cooling. Leakage of vacuum equipment or piping. Continuous repetition of startup/shutdown. Extraordinarily-high temperature.
Overheating inside the STP control unit	90 or more in the STP control unit and heat sink.	"FAILURE"	"ALARM"	The STP pump stops.	Failure in the cooling fan. Shielding of cooling air inlet and ventilation port. Extraordinarily-high temperature
Overspeed	Rotational speed of the STP pump:37,500 rpm or more.	"FAILURE"	"ALARM"	The STP pump stops.	Failure in the inverter.
Abnormal battery terminal voltage	Battery terminal voltage: 42 V or lower*1	"FAILURE" *2 ("EMERGENCY OPERATION" or "BATTERY NG" lamp may light)	"ALARM"	The STP pump does not start.	Incorrect connection of the battery. Battery capacity became less than operating limit value.

*1 : When capacity of battery is less than operating limit value largely, there may be the thing that battery abnormal detection does not operate.

*2 : When the power is turned on again, this lamp goes out.

7 Gas Suction, Cooling and Baking the STP Pump

7.1 Gas Suction



When sucking gases, they may remain in the STP pump. Introduce a purge gas and then exhaust all gasses.
Residual gases in the STP pump may cause an accident when the STP pump is removed.
Confirm the characteristics of gases to be used, referring to the Material Safety Data Sheet (MSDS) you obtain from the gas supplier.



Chlorine or fluorine system gases can be used in the chemical specific STP-H600C/H1000C (type C). When you use gases including alkaline metals, but excluding Li, gases including Ga, Hg, In, or Sn, or HBr, contact Seiko Seiki.

NEVER use corrosive gases (chlorine, fluorine, or other system gases) in the STP-H600/STP-H1000 pump or other models without anti-corrosion treatment.

Cool the STP pump to within the operating pressure range to prevent the STP pump from overheating when sucking gases.

7.1.1 How to Introduce a Purge Gas

When sucking reactive or corrosive gases, introduce a purge gas to protect the inside of the STP pump.

- 1) Connect a needle valve or a similar part to the purge port and introduce a dry N₂ gas or other gas to perform a gas purge (See Section 3.3.6, "Connecting the Purge Port").
- 2) The proper amount of the gas purge is approx. 3.4×10^{-2} Pa·m³/s (20SCCM). The allowable gas pressure ranges from zero [atmospheric pressure] to 4.9×10^4 Pa [gauge pressure] (zero [atmospheric pressure] to 0.5kgf/cm² [gauge pressure]).



When not using the purge port, always mount the blank flange (attached at delivery).

High-pressure at the inlet port may result in a noise. This is no abnormality/error.

7.2 Cooling the STP Pump

There are two methods for cooling: Water cooling and Air cooling.
 When sucking gases, cool the STP pump in accordance with the operating pressure range.
 Also, when performing baking, always cool the STP pump.
 Select the best one which fits your vacuum equipment.

7.2.1 Water Cooling Method

- 1) Connect the cooling water pipe to the cooling water port in accordance with Figure 7.1.
- 2) The female screw PT*1 (RC)1/4 is used in the cooling water port (see Figure 16.1, "External Appearance of the STP Pump").
- 3) Use connection hose of ID (internal diameter) 8 mm, and secure it to prevent water leakage.
- 4) Use cooling water under the following conditions:

Amount of water:	2 L/min
Temperature:	5 to 25
Water pressure:	$2.9 \times 10^5 \text{Pa}$ (3kgf/cm ²) or lower



Use clean water as much as possible.
 Cooling water containing foreign materials may corrode or clog the cooling water pipe.
 When the cooling system is clogged with foreign materials, clogs may possibly be removed by feeding cooling water reversely.

When the STP pump is overheated due to shortage or suspension of water, the protective function detects the overheated condition in the STP pump and stops the STP pump.

As a further safety procedure, attach a flow switch to the cooling water exit so that the STP pump stops if abnormal cooling water flow occurs (a flow switch is available on the market).

When the STP pump is not to be used for a long period of time or it is to be moved after use, introduce compressed air from one side of the inlet/outlet port so that no water will remain inside.

The joint for water cooling unit is made of brass. To prevent corrosion, connect the brass joint.

*1: JIS

7.2.2 Air Cooling Method

When water cooling is not available, an air cooling unit (optional accessory) can be used. Follow the steps below:

- 1) Remove the water cooling unit (it is attached with the four M8^{*1} screws).
- 2) Attach the air cooling unit using screw holes for the water cooling unit.



Check the rated voltage of the air cooling unit before use.

Purchase a breaker or fuses for the air cooling unit (remote terminal block TB2 incorporates fuses).

When connecting the power for the air cooling unit (over 25 V AC) to the remote terminal block, secure the cable using the attached cable fitting tool. DO NOT apply excessive force to the cable for the air cooling unit.

Follow the steps below to run the STP pump associated with the air cooling unit (read through Section 8, "Remote Input/Output Signal Terminal Blocks," then operate them).

- 1) Connect the power cable of the air cooling unit between "I/O TB2 FAN OUT Terminal (5) - (6)."
- 2) Input the power supply of the air cooling unit between "I/O TB2 AC. POWER IN Terminal (19) - (20)."
- 3) The air cooling unit functions under the "ACCELERATION" or "NORMAL OPERATION" state.
- 4) The air cooling unit also stops when the STP pump stops.

*1: JIS

7.3 Baking the STP Pump

To attain a lower pressure in a shorter time and reduce the exhaust time, bake the vacuum equipment and STP pump.



The surfaces of the STP pump and its peripheral equipment will become extremely hot when performing baking. NEVER touch them with bare hands.



When baking the STP pump, always cool it to prevent overheating (for the cooling method, see Section 7.2, "Cooling the STP Pump").

Start baking after cooling is started.

Set the temperature of the baking heater to 120 °C or lower (an optional baking heater is set to 110 °C or lower).

DO NOT suck gases during baking to prevent overheating.



To exhaust the gas discharged from the vacuum equipment and the inner wall of the STP pump, run the STP pump during baking.

7.3.1 Attaching a Baking Heater

- 1) Attach a baking heater (optional accessory) as near as possible to the inlet port flange.
- 2) Affix the "Hot Surface Warning Label" to the surface of the STP pump so that the operator can see it clearly at any time.



Check the rated voltage of the baking heater before use.

Wind the baking heater around the surface of the STP pump tightly. If the baking heater is not wound tightly, the loose parts will overheat.

Procure protective parts for the baking heater, such as a residual current operated circuit breaker and fuses when using the baking heater (remote terminal block TB2 incorporates fuses).

DO NOT apply excessive force to the cable for the baking heater.

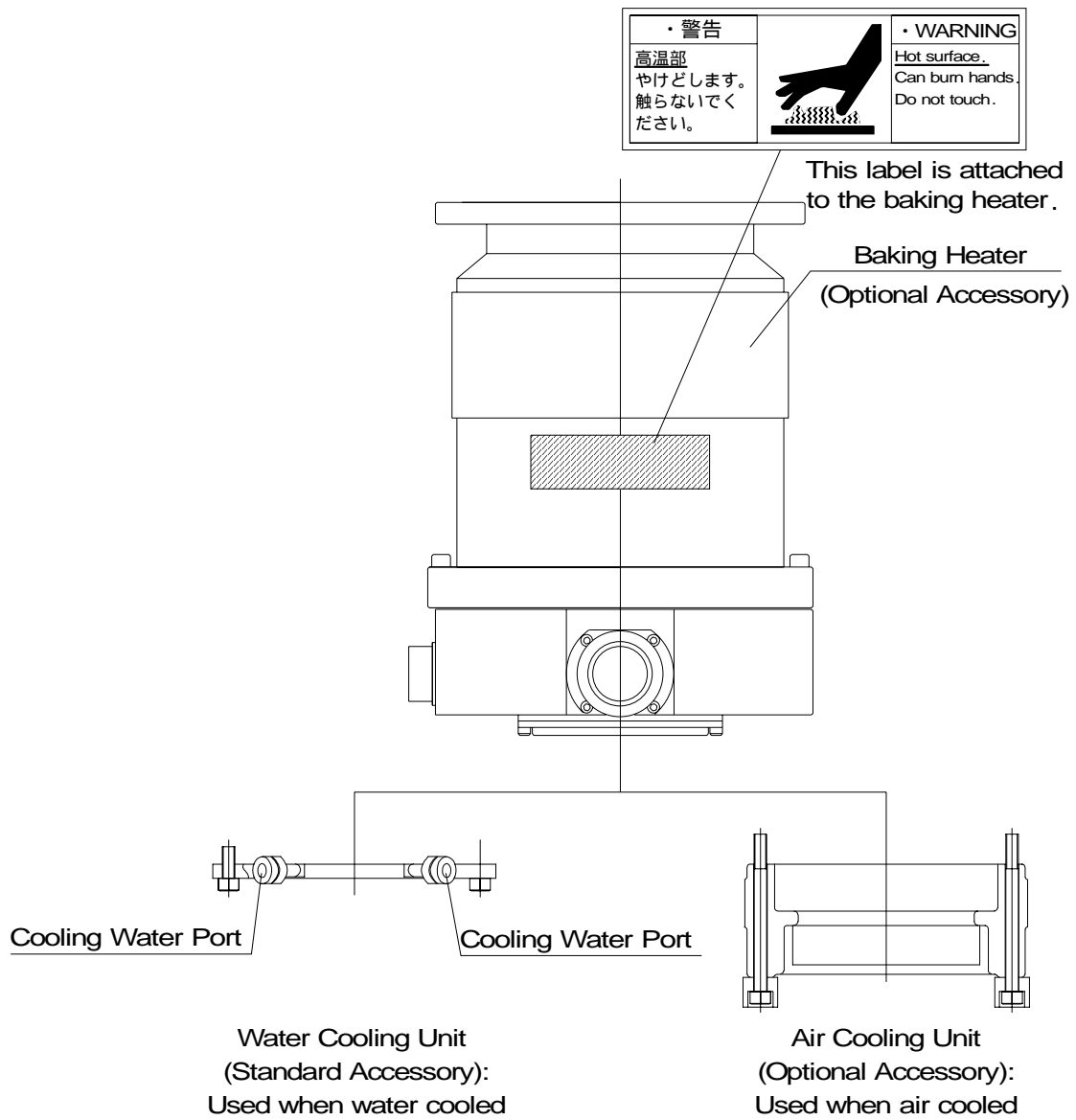

Table 7.1 Attaching Positions of the Cooling Unit and Baking Heater

7.3.2 Interlocking the STP Pump Operation with Baking

Follow the steps below to interlock the STP pump operation with baking (read through Section 8, " Remote Input/Output Signal Terminal Blocks," then start operation).



Check the rated voltage of the baking heater before use.

Always turn OFF the power to the remote terminal block from equipment, before connecting/disconnecting the remote wire to the remote terminal block. Failure to do so may result in electric shock.

When connecting the power for the baking heater (over 25 V AC) to the remote terminal block, secure the cable using the attached cable fitting tool. DO NOT apply excessive force to the cable for the baking heater.

- 1) MANUAL OPERATION (See Section 8.1, "I/O TB2 Terminal Block.")
 - (1) Connect the power cable of the baking heater between "I/O TB2 HEATER OUT Terminals (1) - (2)."
 - (2) Input the power supply of the baking heater between "I/O TB2 AC. POWER IN Terminals (19) - (20)."
 - (3) Press the HEATING ON/OFF switch (an alternate type) under the NORMAL OPERATION state (the HEATING ON/OFF switch built-in green lamp lights. The heater is "ON" while the lamp is being lit).
 - (4) Press the HEATING ON/OFF switch under any state other than the NORMAL OPERATION. The HEATING ON/OFF switch built-in green lamp lights and the baking heater functions under the NORMAL OPERATION state.

- 2) REMOTE OPERATION (See Sections 8.1 and 8.2, "I/O TB2 Terminal Block" and "DC I/O TB3 Terminal Block.")
 - (1) Perform the same steps (i, ii) as for the MANUAL OPERATION.
 - (2) Short the circuit between "I/O TB3 HEATING Terminals (2) - (4)" (the HEATING ON/OFF switch built-in green lamp lights. The heater is "ON" while the lamp is being lit).
 - (3) Short the circuit between "I/O TB3 HEATING Terminals (2) - (4)" under any state other than the NORMAL OPERATION state.
 - (4) The HEATING ON/OFF switch built-in green lamp lights and the baking heater functions under the NORMAL OPERATION state.



The baking heater functions only while the STP pump is under the NORMAL OPERATION state.

8 Remote Input/Output Signal Terminal Blocks

8.1 I/O TB2 Terminal Block

This is a terminal block for a remote output signal. Use it in accordance with Table 8.1 and Figure 8.1. The terminal block functions in both the MANUAL and REMOTE operations.

The screw for the terminal is M3*1.

Five abbreviations are used in the following tables:

- N.O :Normal Open N.C :Normal Close COM :Common
- IN :Input Terminal OUT : Output Terminal
- L1 :Hot N1: Neutral (or Grounded Supply)



Always turn OFF the power to the remote terminal block from equipment, before connecting/disconnecting the remote wire to the remote terminal block. Failure to do so may result in electric shock.

When connecting optional power (over 25 V AC or over 60 V DC) to terminals (1) to (6), (19) and (20), secure the remote cable using the attached cable fitting tool (see Figure 8.3).

DO NOT apply excessive force to the remote cable.



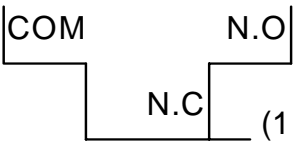
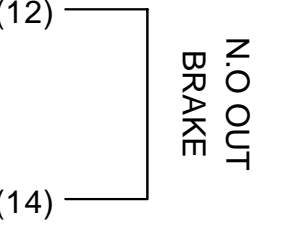

Table 8.1 I/O TB2 Terminal Block

Terminal	Description
<div style="text-align: center;"> (20) AC.POWER (19) </div>	Terminal for inputting power for driving the baking heater, auxiliary pump and air cooling unit. The voltage input to this terminal is output to the specified terminal block through operation of the STP pump. Connect hot to terminal (19)[L1]. Connect neutral (or grounded supply) to terminal (20)[N2].
<div style="text-align: center;"> (2) HEATER (1) </div>	Terminal for connecting the baking heater. In either case of the following two types of operation under the NORMAL OPERATION state, voltage input to the AC power terminal ((19)-(20)) is output to this terminal. 1) Turn ON the HEATING switch on the front panel through MANUAL Operation. 2) Short the circuit between I/O TB3 HEATING terminal (2)-(4) through REMOTE Operation (See Section 7.3.2, "Interlocking the STP Pump Operation with Baking").
<div style="text-align: center;"> (4) R.PUMP (3) </div>	Terminal for starting the auxiliary pump. The voltage input to the AC. POWER terminal ((19)-(20)) is output to this terminal through the STP pump rotation. DO NOT connect the auxiliary pump directly. Use separate power and a relay. Use another power and a relay. See Figure 8.2.



If the I/O TB3 ((1)-(3)) is opened, it is diagnosed as abnormal auxiliary pump, the "FAILURE" lamp lights and the power is cut OFF.

*1: JIS

Terminal	Description
<p>(6) FAN (5)</p> <p>N.O OUT</p> 	<p>Terminal for connecting the air cooling unit. The voltage input to AC. POWER terminal ((19)-(20)) is output to this terminal when the STP pump is in acceleration or rated operation. The voltage is cut OFF when the STP pump is under the BRAKE state (See Section 7.2.2, "Air Cooling Method").</p>
<p>(8) POWER (7)</p> <p>N.O OUT</p> 	<p>Terminal for outputting the POWER ON state signal. This terminal is closed when the magnetic bearing functions and the rotor levitates.</p>
<p>(10) ALARM OUT (9)</p> <p>COM N.O</p> <p>N.C (11)</p> 	<p>Terminal for outputting the ALARM signal. When an abnormality/error is detected under the POWER ON state, the terminal between (10)-(9) is closed, and the terminal between (10)-(11) is opened.</p>
<p>(12) N.O OUT BRAKE (14)</p> 	<p>Terminal for outputting the BRAKE state signal. This terminal is closed when the STP pump is in brake.</p>
<p>NORM OUT (13)</p> <p>COM N.C (15)</p> <p>(16)</p> 	<p>Terminal for outputting the NORMAL OPERATION state signal. When the STP pump is in rated operation, the terminal between (16)-(13) is closed, and the terminal between (16)-(15) is opened.</p>
<p>(18) POWER (17)</p> <p>N.O OUT</p> 	<p>Terminal for outputting the ACCELERATION state signal. This terminal is closed when the STP pump is in acceleration.</p>

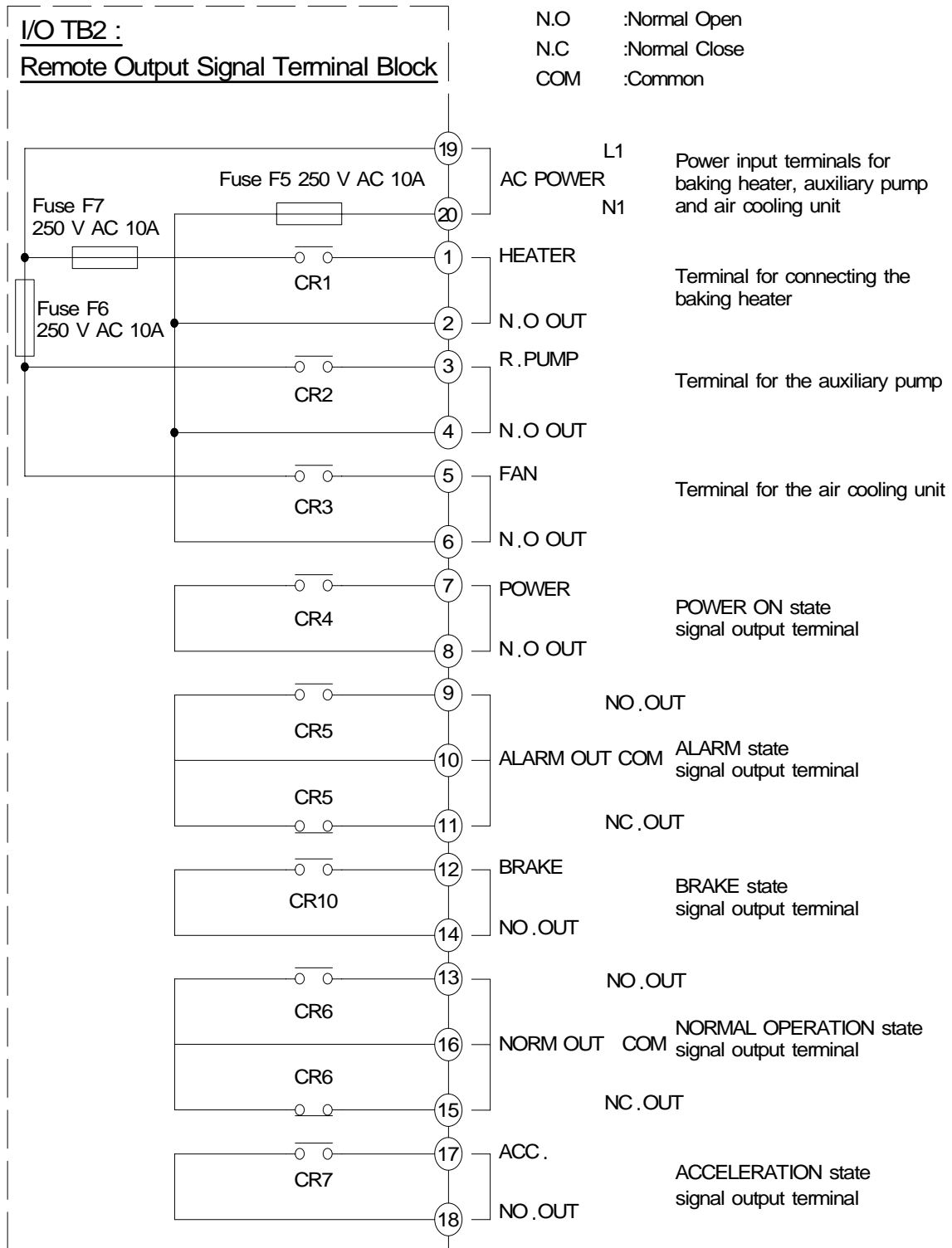

Figure 8.1 I/O TB2 Remote Output Signal Terminal Block

Table 8.2 shows rated contacts for relays CR1 to 4, CR7, and CR10 (See Figure 8.1) and CR8 (See Figure 8.4).

Table 8.2 Rated Contacts for Relays CR1 to 4, CR7, CR8 and CR10

	Resistance Load (cos =1)	Induction Load (cos =0.4) (L/R=7 ms)
Rated Load	250 V AC 10 A 30 V DC 10 A	250 V AC 5A 30 V DC 5A
Rated Current	10 A	
Maximum Contact Point Voltage	380 V AC 125 V DC	
Maximum Contact Point Current	10 A	
Maximum Open/Close Capacity	AC: 2500 VA DC: 300 W	AC: 1250 VA DC: 220 W
Minimum Applicable Load	5 V DC 10 mA	

Table 8.3 shows rated contacts for relays CR5 and 6 (see Figure 8.1).

Table 8.3 Rated Contacts for Relays CR5 and 6

	Resistance Load (cos =1)	Induction Load (cos =0.4) (L/R=7 ms)
Rated Load	250 V AC 10 A 30 V DC 10 A	250 V AC 7.5 A 30 V DC 5A
Rated Current	10 A	
Maximum Contact Point Voltage	380 V AC 125 V DC	
Maximum Contact Point Current	10 A	
Maximum Open/Close Capacity	AC: 2500 VA DC: 300 W	AC: 1875 VA DC: 150 W
Minimum Applicable Load	5 V DC 100 mA	

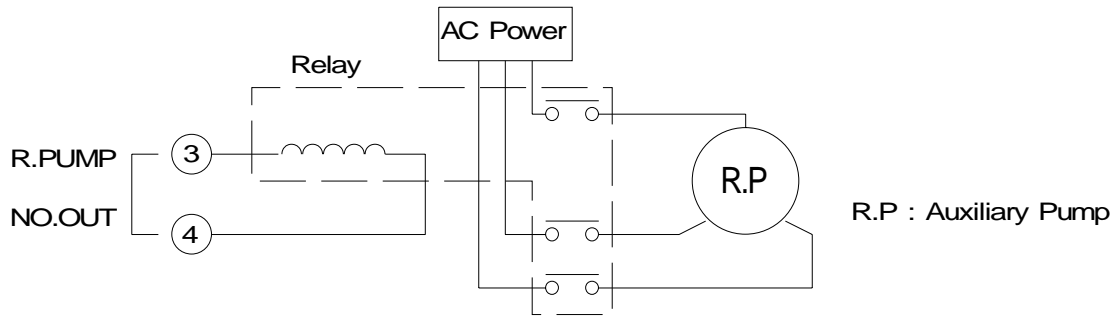

Figure 8.2 Example of Connecting I/O TB2 R. Pump Terminal

CAUTION

When connecting optional power (over 25 V AC or over 60 V DC) to terminals (1) to (6), (19) and (20), secure the remote cable using the attached cable fitting tool (see Figure 8.3).

DO NOT apply excessive force to the remote cable.

DO NOT disconnect the ground cable for the metallic terminal block cover.

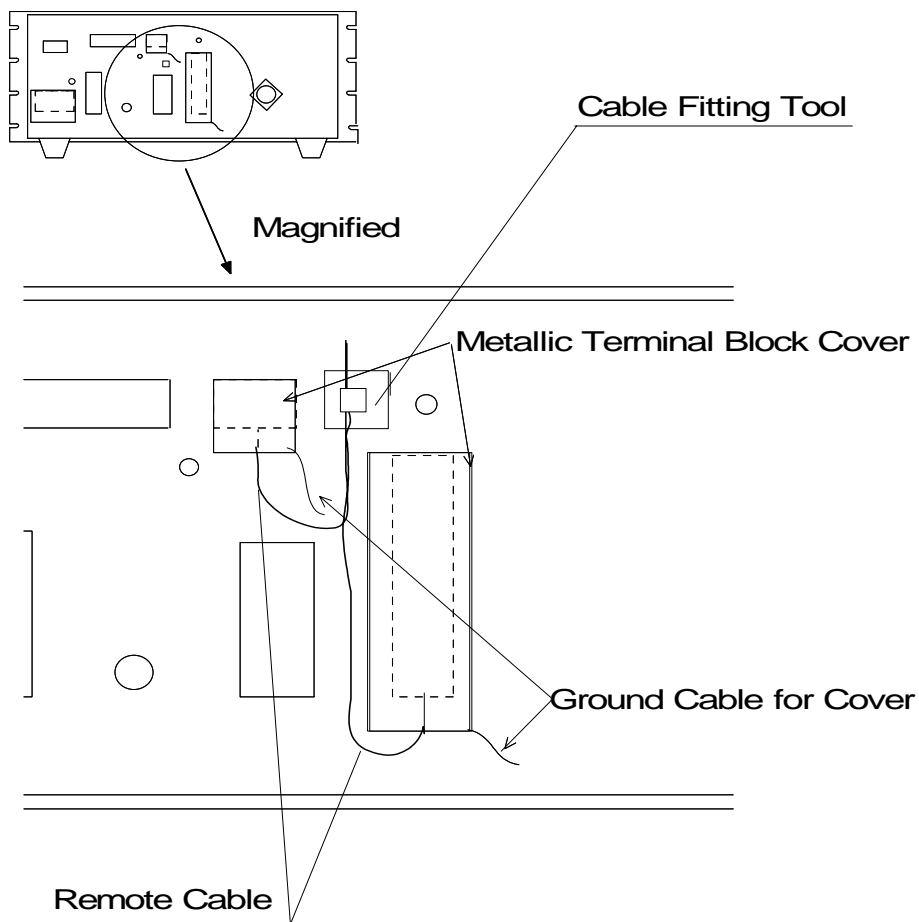

Figure 8.3 Example of Securing the Remote Cable

8.2 DC I/O TB3 Terminal Block

This is a terminal block for a remote input/output signal. Use it in accordance with Table 8.4 and Figure 8.4. Terminals excluding the HEATING terminal function in either case of the REMOTE/MANUAL operation.

The screw for the terminal is M3*1.

Four abbreviations are used in the following tables:

- N.O :Normal Open N.C :Normal Close
- IN :Input Terminal OUT :Output Terminal.

Table 8.4 DC I/O TB3 Terminal Block

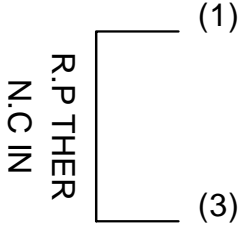
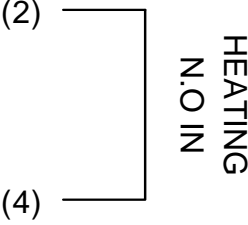
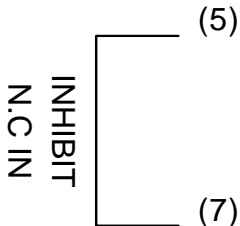
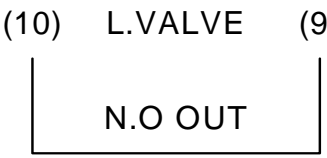
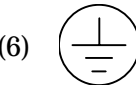
Terminal	Description
	<p>Terminal for connecting the thermal switch to protect the auxiliary pump.</p> <p>When the normal close type thermal switch for protecting the auxiliary pump is connected between this terminal, short the circuit between I/O TB2 R.PUMP terminal (3)-(4) and stop the auxiliary pump. The "FAILURE" lamp lights.</p> <p>When this function is not used, short the circuit between (3)-(4) (shorted at delivery).</p>
	<p>Terminal for baking heater remote control.</p> <p>When the circuit between this terminal is shorted through the "REMOTE" operation, the voltage for the baking heater is output between I/O TB2 HEATER terminal (1)-(2) during rated operation.</p>
	<p>Terminal for inputting the rotation INHIBIT signal. When the terminal is set to open, the STP pump does not rotate despite the STP pump operation.</p> <p>And only the auxiliary pump start voltage is output to I/O TB2 R.PUMP terminal ((3)-(4)).</p> <p>When this function is not used, short the circuit between (5)-(7) (shorted at delivery).</p>
	<p>Terminal for the emergency vent. valve operation signal. This terminal is closed while the emergency vent. valve is opened.</p>
	<p>Ground</p>
<p>(8)</p>	<p>Not-used</p>

*1: JIS

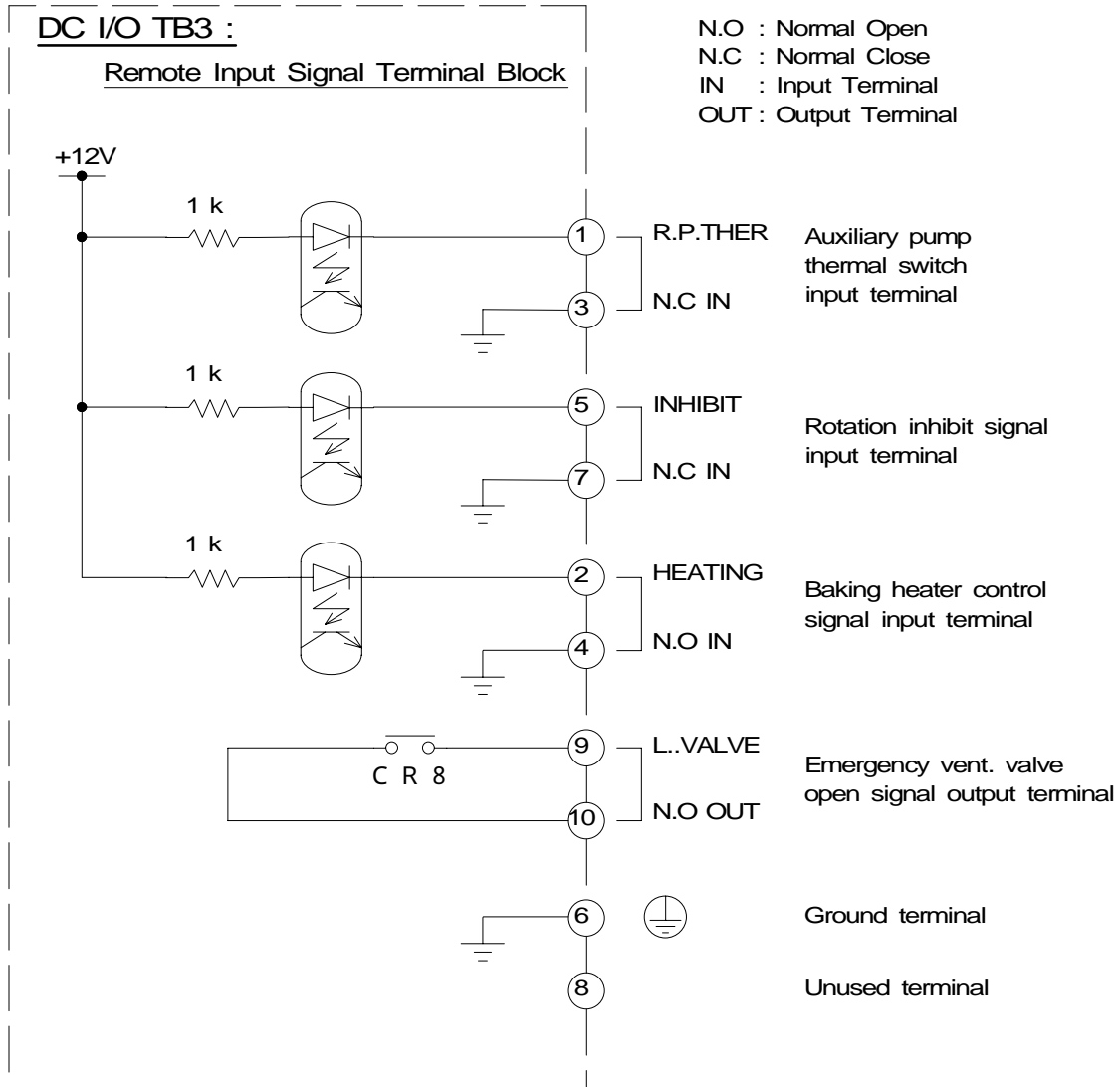

NOTICE

Short the circuit between (1)-(3), when the R.P.THER terminal is not used.

Short the circuit between (5)-(7), when the INHIBIT terminal is not used.

See Table 8.2 for the contact ratings of relay CR8.

Figure 8.4 DC I/O TB3 Remote Input Signal Terminal Block

8.3 START STOP TB5 Terminal Block



This is a terminal block for a contact type remote input signal. Use it in accordance with Table 8.5 and Figure 8.5 (See Section 5.6.2, "Starting/Stopping the STP Pump"). The terminal block operates only during the REMOTE operation.

The screw for the terminal is M4*1 .

Three abbreviations are used in the following tables:

- N.O :Normal Open N.C :Normal Close
- IN :Input Terminal

Table 8.5 START STOP TB5 Terminal Block

Terminal	Description
	<p>Terminal for the START signal input terminal. The following two methods are available:</p> <ol style="list-style-type: none"> 1) Short the circuit between terminals ((2)-(3)) for 0.3 seconds or more. When this signal is input simultaneously with switching ON the breaker on the rear panel, short the circuit for 5 seconds or more. 2) Short the circuit between terminals ((1)-(3)). In this case, terminal (2) is not used.
	<p>Terminal for the STOP signal input terminal. The STOP signal has priority for the START signal. During the START operation input from terminal (1)-(2) of the START/STOP TB6 terminal block, the STP pump does not stop.</p> <ol style="list-style-type: none"> 1) In case of above 1): Rotation will stop when the circuit between this terminal is opened. 2) In case of above 2): Rotation will stop when the circuit between terminal (1)-(3) is opened.

START STOP TB5 Remote Input Signal Terminal Block

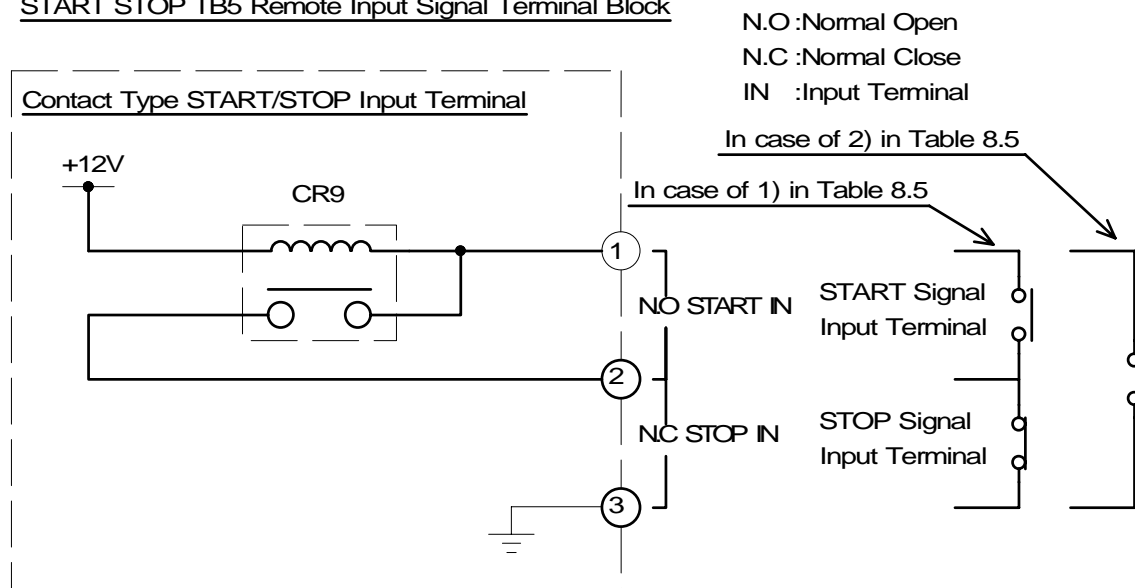

Figure 8.5 START STOP TB5 Remote Input Signal Terminal Block

*1: JIS

8.4 START/STOP TB6 Terminal Block

This is a terminal block for a voltage type remote input signal.

Use it in accordance with Table 8.6 and Figure 8.6 (See Section 5.6.2, "Starting/Stopping the STP Pump").

The terminal block operates only during REMOTE operation.

The screw for the terminal is M4*1 .



When connecting optional power (over 25 V AC) to terminals (1) or (2), secure the remote cable using the attached cable fitting tool (See Figure 8.3). DO NOT apply excessive force to the remote cable.

DO NOT disconnect the ground cable for the terminal block cover.

Table 8.6 START/STOP TB6 Terminal Block

Terminal	Description
<div style="display: flex; justify-content: space-around; align-items: center;"> <div style="text-align: center;">(1)</div> <div style="text-align: center;">(2)</div> </div>  <p style="text-align: center;">START/STOP IN</p>	<p>Terminal for the voltage type START/STOP signal terminal. When the voltage of 25 to 250 V AC or 24 to 48 V DC is applied between these terminals, the STP pump starts. When the circuit between these terminal is opened, the STP pump stops.</p> <p>In case of DC input, the STP pump can start to rotate by connecting the plus (+) side either to (1) or (2).</p>

START/STOP TB6 Remote Input Signal Terminal Block

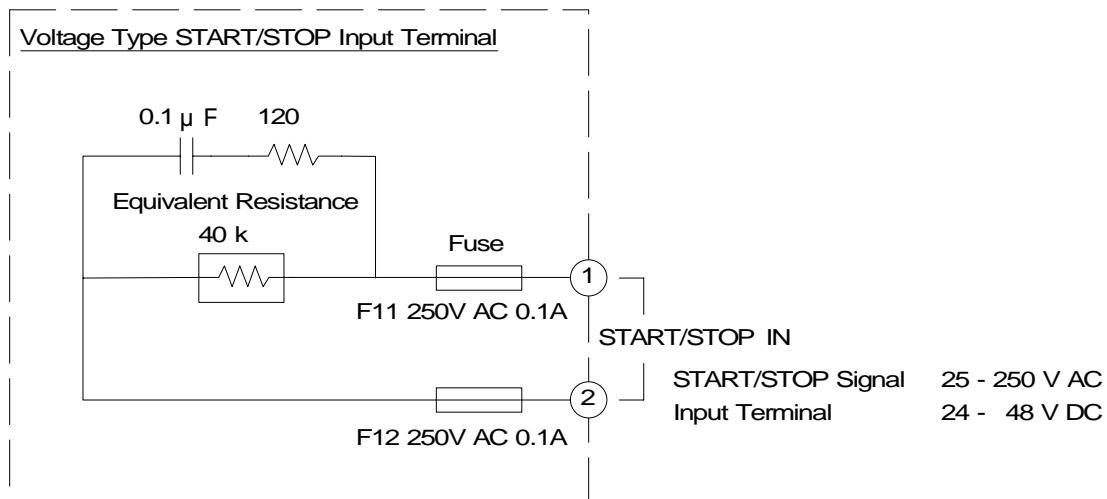

Figure 8.6 START/STOP TB6 Remote Input Signal Terminal Block

*1: JIS

9 Internal Battery

Four batteries (PORTALAC Series Small-Sized Sealed Lead-Acid Batteries, PE12V 2WS : 12V, 2Ah, manufactured by Japan Storage Battery Co., Ltd.) (hereinafter referred to as the internal battery) are inserted into the STP pump for backup during a power failure. These are rechargeable. During a power failure, power is supplied from the batteries, and levitation by a magnetic bearing continues for 6 minutes while the pump is decelerating and the rotor is landing.

Fully-charged batteries are capable of consecutively backing up the operation of the STP pump twice.



Do not use unspecified battery.

If you use unspecified battery, contact Seiko Seiki before use.

9.1 Life of the Internal Battery

The life of the internal battery is affected by ambient temperatures.

Pay attention to ambient temperatures (the operating ambient temperatures range from 0 to 40 °C).

Figure 9.1 shows the relationship between the ambient temperatures and the battery life.



Replace the battery approx. once a year to make sure it is always ready to back up the operation of the STP pump.

For instructions on how to replace the battery, see Section 9.5, "How to Replace the Internal Battery."

9.2 Allowable Shelf Life of the Internal Battery

When the internal battery is left uncharged, its capacity will be reduced by self-discharge.

The allowable shelf life of the internal battery is affected by ambient temperatures. Pay attention to its storage temperatures (the storage temperatures range from - 20 to + 40 °C).

Figure 9.2 shows the relationship between storage temperatures and the allowable shelf life of the internal battery.



When the STP pump is left unused over the specified period, charge the internal battery for 90 minutes or more, or replace it with a new one before starting the STP pump. For instructions on how to recharge the internal battery, see Section 9.3, "How to Charge the Internal Battery." For instructions on how to replace the internal battery, See Section 9.5, "How to Replace the Internal Battery."

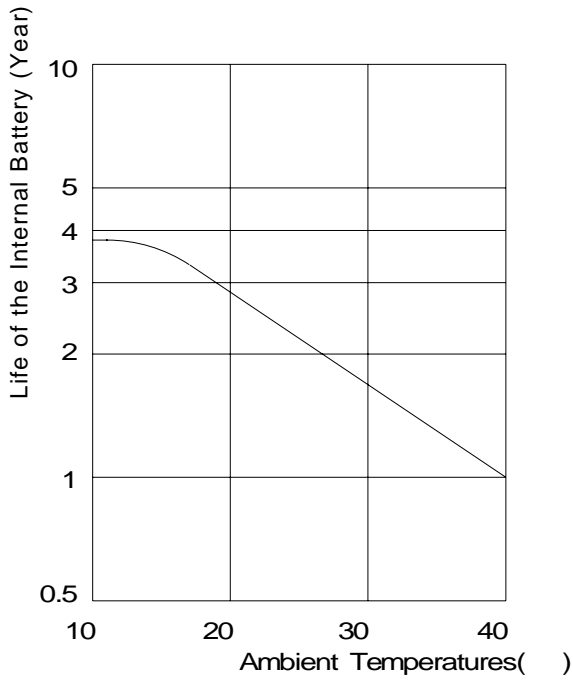

Figure 9.1 Life of the Internal Battery

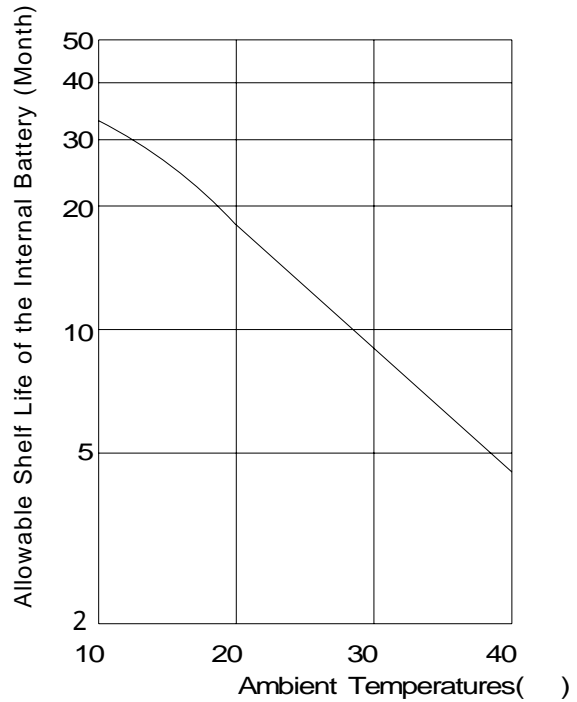

Figure 9.2 Allowable Shelf Life of the Internal Battery

9.3 How to Charge the Internal Battery

The battery is charged while the power is "ON," regardless of the operation state of the STP pump.

After a power failure, charge the battery for approx. 12 times the BATTERY BACKUP time. For example, when the BATTERY BACKUP time is 6 minutes, it takes approx. 75 minutes to charge the battery.

If a power failure occurs 2 times within 90 minutes, charge the battery for more than 90 minutes before starting to operate the STP pump.

9.4 BATTERY NG Lamp

If battery capacity became less than operating limit value or there was connection mistake, the "BATTERY NG" lamp on the rear side of the STP control unit front panel (See 9.3, "Life of the Internal Battery"), the "FAILURE" lamp, and the "EMERGENCY OPERATION" lamp on the STP control unit front panel light, and the STP pump does not start.

Replace the battery with a new one and reset the "Battery Capacity Low Warning" (BATTERY NG) lamp.

However, when capacity of battery is less than operating limit value largely, there may be the thing that battery abnormal detection does not operate.

For instructions on how to replace the battery and restart the STP pump, see 9.5 "How to Replace the Internal Battery "



When the " BATTERY NG" lamp lights, always replace the internal battery with a new one.

"BATTERY NG" lamp does not indicate the battery exchange time beforehand. There is the case that battery deteriorates even if this lamp does not turn on. According to 9.1 "Life of the internal Battery", change battery regularly.



When the power is turned on again, the "FAILURE" lamp goes out.

9.5 How to Replace the Internal Battery

When covering the battery case, be sure not to catch the battery cable in the battery case. Failure to do so may shortcircuit the battery and result in a leakage, production of fire or explosion.



Turn OFF the primary power (Switch the breaker "OFF"), before replacing the battery.

Failure to do so may result in product damage or a problem due to electric shock or short-circuiting of the internal circuit.

DO NOT touch any portions other than those designated.

Careless touch may cause electric shock and/or a short-circuiting of the internal circuit, resulting in product damage or a problem.

DO NOT use a new battery and a worn-out battery simultaneously.

DO NOT use different types of batteries simultaneously.



When replacing the battery, record the next replacement date of the battery on the "Battery Instruction Label" (See Figure 9.3) on the front panel.

The first replacement date of the battery has been specified on the "Battery Instruction Label" (See Figure 9.3) on the front panel at delivery.

9.5.1 How to Replace the Battery Case

- 1) Stop the STP pump, and turn OFF the primary power (switch the breaker "OFF").
- 2) Unscrew the 4 screws attached to front panel (1) and bring the front panel down towards you.
- 3) Disconnect internal battery connector (2) (CON12).
- 4) Unscrew battery case screws (3) and pull out battery case (4) from the STP control unit.
- 5) Replace battery case (4) containing a new battery.
- 6) Tighten battery case screw (3) and secure the battery case (4).
- 7) Connect internal battery connector (2) (CON12).
- 8) Turn ON the primary power (switch the breaker "ON") as well as the POWER switch. Then, check whether or not "BATTERY NG" lamp (7) on the rear side of the front panel lights.
- 9) If "BATTERY NG" lamp (7) located on the rear of the front panel lights, press RESET switch (8) on the side of "BATTERY NG" lamp (7) to reset it (although an impact noise may generate momentarily during reset, it is not indicative of a problem).
- 10) Turn OFF the POWER switch and the primary power (Switch the breaker "OFF").
- 11) Close front panel (1) and tighten the 4 screws that secure the front panel.
- 12) Record the next replacement date (after one year) of the battery on "Battery Instruction Label" (9) attached to the front panel (See Figure 9.3).

9.5.2 How to Replace the Battery in the Battery Case

- 1) Remove front plate (5) from battery case (4) by unscrewing 4 M2 screws.
- 2) Disconnect battery internal connector (6).
- 3) Remove inside plate(10) from battery case by unscrewing 4 M2 screws and pull out the battery from the case (it can be pulled out toward you).
- 4) Replace the four worn-out batteries with new ones, the side, from which the cord projects, up.
- 5) Attach inside plate(10).
- 6) Connect battery internal connector (6) and attach front plate (5) to the battery case (Be careful not to catch the cable).



When covering the battery case, be sure not to catch the battery cable in the battery case. Failure to do so may shortcircuit the battery and result in a leakage, production of fire or explosion.



New batteries and battery cases are supplied by Seiko Seiki.

(1)	STP Control Unit Front Panel
(2)	Internal Battery Connector
(3)	Battery Case Screw
(4)	Battery Case
(5)	Battery Case Front Plate
(6)	Battery Internal Connector
(7)	BATTERY NG Lamp
(8)	RESET Switch
(9)	Battery Instruction Label
(10)	Battery Case Inside Plate
(11)	Flat Head Screw (M2)

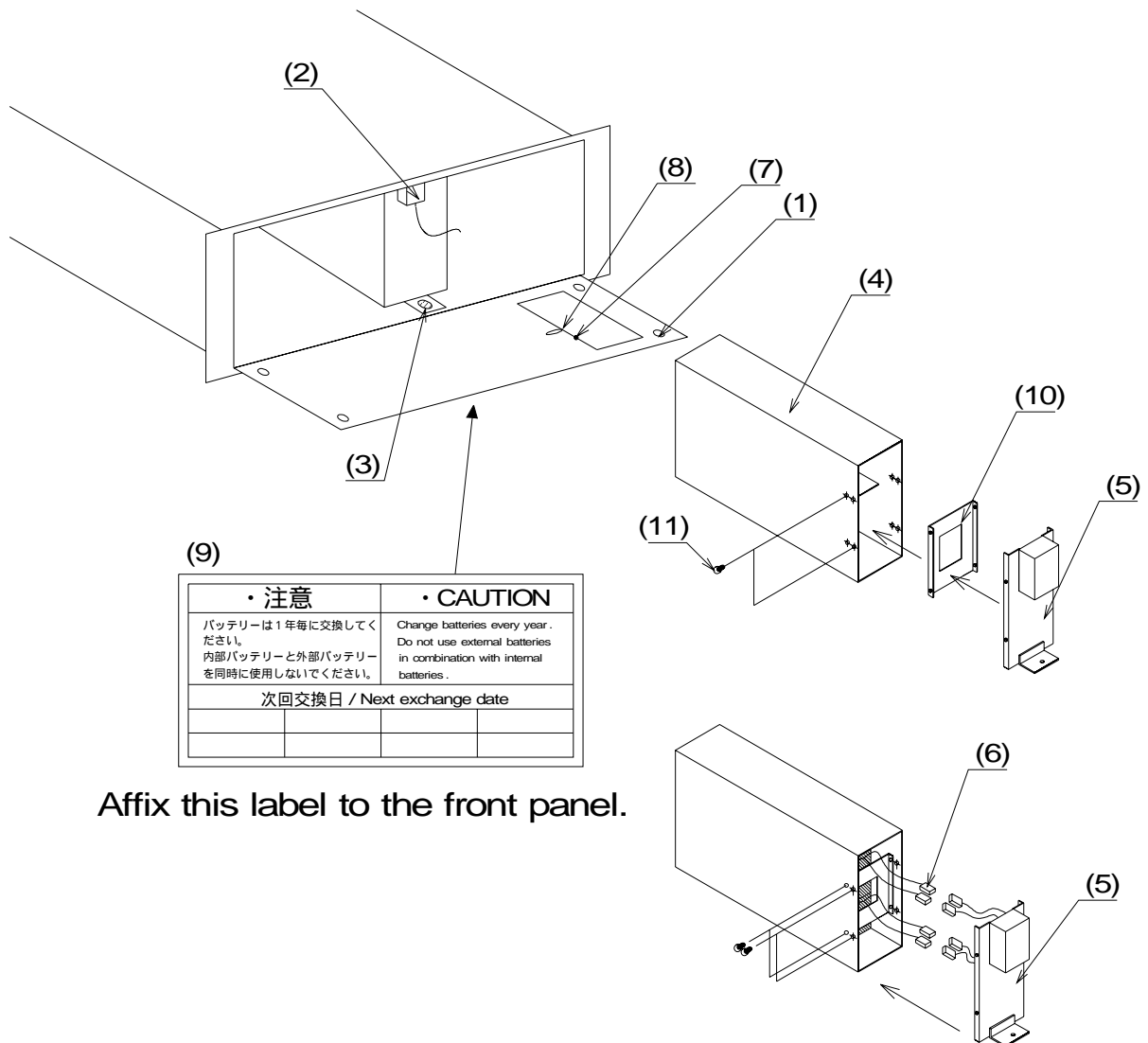

Figure 9.1 How to Replace the Internal Battery

9.6 How to Dispose of the Internal Battery

Dispose of or collect worn-out batteries in accordance with the guidelines given by each national and/or local government. If you procure batteries, dispose of them in accordance with the guidelines given by the battery manufacturer.



Pay attention to short-circuiting or leakage of the batteries when disposing of them.

To prevent the batteries from short-circuiting, remove the lead wires and connectors from the batteries.

Cut the lead wires one by one so as not to cause a short-circuiting.

Coat the conductive part of the batteries with tape.



It is recommended to dispose of worn-out batteries after discharging them thoroughly.

Batteries manufactured by Japan Storage Battery Co., Ltd. will be collected by Japan Storage Battery Co., Ltd. For detailed information, contact Japan Storage Battery Co., Ltd. or Seiko Seiki.

10 External Battery



DO NOT use (an) external batteries when internal batteries are inserted. Failure to do so may result in product damage or a problem. It could cause a problem, such as product damage.

DO NOT connect batteries in parallel.

Replace batteries with new ones before the end of their life.

When the STP pump is left unused over the specified period, charge battery for 90 minutes, or replace it with a new one before starting the STP pump.



The life, allowable shelf life, and operation frequency of the battery differ depending upon the type of the battery and ambient temperatures. See technical data and information prepared by the battery manufacturer.

10.1 Specifications for the External Battery

When you use external batteries, select one in accordance with the specifications given in Table 10.1.



If you use external batteries which do not conform to the specifications, battery backup will not function during a power failure which could result in damage to the STP pump.

Table 10.1 Specifications for the External Battery

Item	Specifications
Capacity	1.8 Ah or more
Voltage	48 V
Current	2.3 A
Operation time	Approx. 6 minutes
Operation frequency	Continues 2 times or more
Charging voltage	55 V

It is recommended to use PORTALAC Series Small-Size Sealed Lead-Acid Battery manufactured by Japan Storage Battery Co., Ltd. as an external battery.

10.2 Installation of the External Battery



Turn OFF the primary power (Switch the breaker "OFF"), before connecting the battery.

Failure to do so may result in product damage or a problem due to electric shock or short-circuiting of the internal circuit.

After disconnecting the internal battery connector (CON12), connect the external battery connector (CON9).

Having both connected simultaneously may result in damage to the STP control unit.

DO NOT use new batteries and worn-out batteries simultaneously.

DO NOT use different types of batteries simultaneously.

If the battery is not securely connected, backup during a power failure does not function.

Install the external battery in accordance with the following steps:

- 1) Stop the STP pump, and turn OFF the primary power (Switch the breaker "OFF").
- 2) Unscrew the 4 screws attached to the front panel and bring it down towards you.
- 3) Pull out the battery according to the method described in Section 9.5.1, "How to Replace the Battery Case," Steps 3) and 4).

Secure the internal battery connector (CON12) so as not to interfere with other parts inside the STP control unit.

- 4) Close the front panel of the STP control unit and tighten the 4 screws that secure the front panel.
- 5) Connect the external battery to the attached external battery plug, paying attention so that "+" and " - " are positioned correctly. "+" and " - " of the external battery plug are represented by (1) and (2), respectively.

CON 9 PIN No.	Polarity of Battery
1	+
2	-

- 6) Connect the external battery plug to the external battery connector (EXT. BATTERY CON9) on the rear panel.
- 7) Record the next replacement date of the battery in the "Battery Instruction Label" (See Figure 9.3) on the front panel for the Next Replacement Date of Battery (See the technical data prepared by the battery manufacturer).

10.3 How to Charge the External Battery



The battery is charged while the power is "ON," regardless of the operation state of the STP pump.

The STP control unit is equipped with a constant voltage (55 V) circuit and a constant current (0.3 A) circuit for charging the battery.

After a power failure, charge the battery for approx. 12 times the BATTERY BACKUP time. For example, if the BATTERY BACKUP time is 6 minutes, it takes approx. 75 minutes to charge the battery.

If a power failure occurs 2 times within 90 minutes, charge the battery for more than 90 minutes before starting the STP pump.

10.4 How to Dispose of the External Battery

Dispose of or collect worn-out batteries in accordance with the guidelines given by each national and/or local government. If you procure the batteries, dispose of them according to the guidelines given by the battery manufacturer.



Pay attention to short-circuiting or leakage of the batteries when disposing of them.

To prevent the batteries from short-circuiting, remove the lead wires and connectors from the batteries.

Cut the lead wires one by one so as not to cause a short-circuiting.

Coat the conductive part of the batteries with tape.



It is recommended to dispose of worn-out batteries after discharging them thoroughly.

Batteries manufactured by Japan Storage Battery Co., Ltd. will be collected by Japan Storage Battery Co., Ltd. For detailed information, contact Japan Storage Battery Co., Ltd. or Seiko Seiki.

11 Operation Principle of the STP Pump

The STP-H600/H1000 is a series of magnetically-levitated turbomolecular pumps, featuring the following:

- Oil free
- Low vibration
- High reliability

The STP pump is configured so that rotor blade (1) and stator blade (2) are aligned alternately in the axial direction. Gas molecules are pumped from the inlet port to the outlet port by the high speed rotation of the rotor.

By uniting the rotor blades and the sleeve lower, the STP pump has a large capacity allowing it to be used in a wide variety of applications. Rotor blade (1) is supported by the magnetic bearing without mechanical contact. Therefore, the STP pump requires no lubrication oil unlike conventional turbomolecular pumps using ball bearings.

The magnetic bearing consists of 5 pairs of active magnetic bearings. The rotor is supported in the radial direction by 4 pairs of radial direction active magnetic bearings that consist of radial sensor (3) and radial electromagnet (4). A pair of axial direction active magnetic bearings consists of axial sensor (5) and axial electromagnet (6) to support the rotor in the axial direction. Because the rotor is supported without mechanical contact, it can rotate at low vibration.

There is less heat generated from magnetic bearings because there is no friction. Therefore the STP pump requires no cooling. However, the STP pump requires water cooling during baking and gas suction. Taking into consideration a breakage of magnetic bearings, touch down bearings (7) and (8) coated with solid lubrication have been installed. They do not contact with the rotor during the rated operation.

A radial direction sensor, a rotation sensor and a temperature sensor always monitor the magnetic bearing as well as the rotor. If an abnormality/error occurs, the rotor will stop.

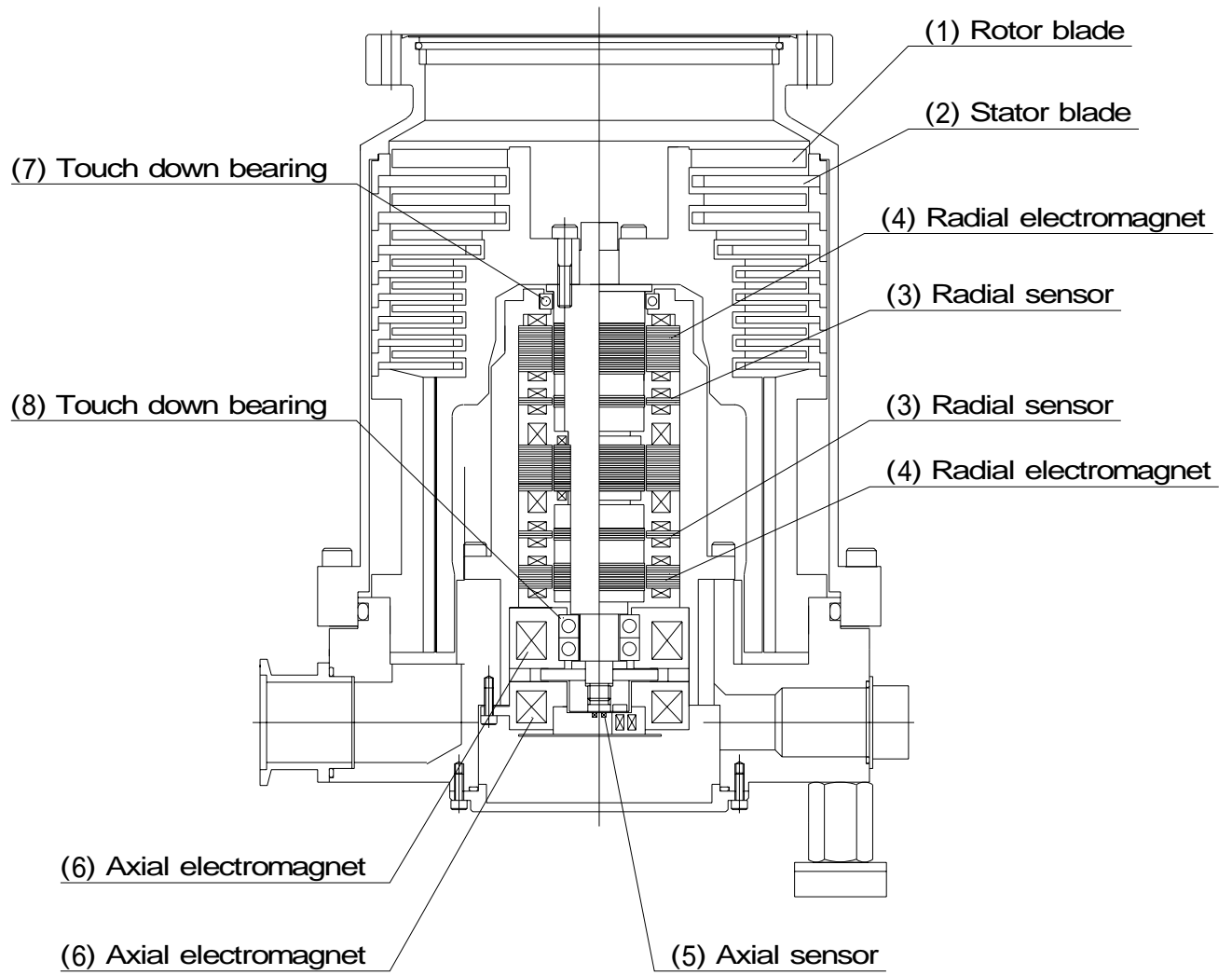

Figure 11.1 Cross Sectional View of the STP Pump

12 Maintenance and Inspection



Stop the STP pump, turn OFF the primary power (switch the breaker "OFF") and disconnect the internal battery connector before performing maintenance of the STP control unit (battery replacement/fuse replacement). Failure to do so may result in an accident such as electric shock.

Stop the STP pump, and turn OFF the primary power (Switch the breaker "OFF") before performing inspections of the STP pump (for deposit). Failure to do so may result in the inadvertent rotation of the STP pump, which may result in an accident.

To inspect the air cooling fan and reset the "BATTERY NG" lamp, always be sure to stop the STP pump, turn OFF the primary power (Switch the breaker "OFF"), open the front panel, then turn ON the primary power. Failure to do so may result in electric shock or product damage due to short-circuiting of the internal circuit.

Before performing maintenance or inspections, power OFF the baking heater and the air cooling unit.

DO NOT touch any of the blocks, parts, or connectors inside the STP control unit (excluding the battery connector). These parts are excluded from maintenance or inspection.

12.1 Replacing the Internal Battery

The STP pump is equipped with rechargeable batteries for backup during a power failure inside the STP control unit. In order to ensure that the battery functions normally during a power failure, replace the batteries before the end of their life (approx. one year).

See Section 9.5, "How to Replace the Internal Battery."

The "Battery Instruction Label" is affixed to the front panel. After replacing the battery, always record the next replacement date.

12.2 Inspecting the Air Cooling Fan

First stop the STP pump. Next turn OFF the primary power (switch the breaker "OFF"), open the front panel, and turn ON the primary power (Switch the breaker "ON"). Confirm that the air cooling fan (See Figure 4.3) inside the STP control unit is operating. Then, turn OFF the primary power (Switch the breaker "OFF") and close the front panel.

If the air cooling fan is not operating, contact Seiko Instruments to replace it.



It is recommended to inspect the air cooling fan when replacing the battery.

12.3 Replacing the Fuses



Remove the probable causes of the blown fuse (Ex. a problem with the remote input signal, etc.) before replacing the fuse.

Always use specified and rated fuses.



If fuses are blown frequently even after they are replaced, contact Seiko Instruments.

The following are protective fuses used in the STP control unit (See Section 4.1.3, "Inside of the Control Unit").

F3, F4: 250 V, 5 A

For control power protection.

F5, F6, F7: 250 V, 10 A (arc-extinguishing fuses)

For I/O TB2 remote input/output terminal protection.

For power input (19) and (20) and power output (1) to (6) protection.

F8: 250 V, 10 A (arc-extinguishing fuse)

For external battery protection.

F9: 250 V, 10 A (arc-extinguishing fuse)

For internal battery protection.

F11, F12: 250 V, 0.1 A

For START/STOP TB6 remote input signal protection.



Two of each three different kinds of fuses are attached for replacement (See Table 16.3).

12.4 Inspecting for Deposit



When inspecting for deposit, exhaust gases inside the STP pump thoroughly. Residual gases may cause an accident when removing the STP pump. Confirm the characteristics of gas to be used, referring to the Material Safety Data Sheet (MSDS) you obtain from the gas supplier. Wear personal protective equipment if necessary.

Leaving the STP pump without removing the deposit may cause the STP pump to be corroded beyond repair.

Deposit may have accumulated inside the STP pump depending upon the type of the vacuum equipment installed in the STP pump. An increase in the amount of deposit may lead to a malfunction of the STP pump.

Therefore, perform regular maintenance (once every 3 to 6 months as a target).

Inspect the inside of the outlet port flange for adhesion of deposit while watching the outlet port flange. If deposit has accumulated to some extent, an overhaul (cleaning) is required. Contact Seiko Instruments.

Note that the costs of troubleshooting problems resulting from deposit will be at your own charge even during the warranty period.

If a problem resulting from deposit occurs inside the STP pump, hermetically seal inlet port, outlet port, purge port, and leak port flanges, and immediately return them to Seiko Instruments.

For the transport method, see Section 12.6, "Transport for Repair or Overhaul."



Contact with atmospheric air may cause a reaction of the deposit. DO NOT open the STP pump to atmospheric air as much as possible.

Seiko Instruments supplies you the Temperature Management System (TMS) unit to keep the temperature high inside the STP pump and prevent the accumulation of deposit.

For details, contact Seiko Instruments.

12.5 Overhaul

The recommended maintenance intervals for different process applications are tabulated below:

	Process	Period	Remarks
Etching*1	Metal Etch	1 year	Ensure that TMS (Temperature Management System) is fitted and operational to prevent accumulation of by-product deposition in the pump.
	Other Etch Processes	2 years	
	It is recommended to change the pump rotor after 5 years due to accumulated wear of the protective plating material		
	Other semiconductor process	2 years	Processes resulting in accumulation of deposits in the pump will require more frequent service.
	Clean applications (Only vacuum pumping)	5 years	
	Other use	(2 years)	Dependent on application, contact Seiko Instruments or our local Service Center.



The touch down bearing inside the STP pump will be worn out after a number of full speed touch downs.

The costs of replacing parts that need to be replaced because of deterioration or abrasion will be at your own charge.

When overhaul of the STP pump or the STP control unit is needed, contact Seiko Instruments or our local Service Center.

*1 "Etching" includes semiconductor etching and LCD etching.

12.6 Transporting for Repair or Overhaul



When removing the STP pump from the vacuum equipment, exhaust gases inside the STP pump thoroughly.
Residual gases may result in an accident when removing the STP pump. Confirm the characteristics of gas to be used, referring to the Material Safety Data Sheet (MSDS) you obtain from the gas supplier.

When returning the STP pump which has used corrosive, reactive or inflammable gases to Seiko Instruments, specify the type of gas and handling precautions on the surface of the package.
Confirm the characteristics of gas to be used, referring to the Material Safety Data Sheet (MSDS) you obtain from the gas supplier.



When returning the STP pump to Seiko Instruments, be sure to pack it well to prevent external damage.

If any of the specifications has not been satisfied, Seiko Instruments will not be responsible for any damage during transport.

i) Always contact Seiko Instruments before returning the STP pump for repairs, overhaul, etc. To avoid any accident by gases or corrosion inside the STP pump, particularly when corrosive, reactive or flammable gases have been used, ii) vacuum and hermetically seal the STP pump before transport. iii) Specify the type of gases used and handling precautions on the package and return the STP pump to Seiko Instruments.

When returning the STP pump to Seiko Instruments, be sure to pack it well to prevent external damage. Use similar or superior packaging material as originally supplied by Seiko Instruments.



The costs of cleaning and overhaul of the STP pump will be at your own charge.

When returning the STP pump to Seiko Instruments, fill in the necessary items in the "STP PUMP PROBLEM CHECK SHEET" and fax it to Seiko Instruments.

13 Storage

13.1 The STP Pump

When the STP pump is left unused over the specified period (more than a few months), follow the precautions below:

- 1) Close the inlet port of the STP pump and vacuum it using an auxiliary pump.
- 2) Purge dry N₂ gas or dry air from the purge port.
- 3) Close the outlet port and purge port.
- 4) If the STP pump is water cooled, introduce compressed air from one side of the cooling water port so that no water remains in the STP pump.
- 5) Store the STP pump in a vertical position.
- 6) DO NOT store the STP pump in the following places:
 - Place of high humidity.
 - (If it must be stored in a place of high humidity, insulate it from the outside and use a dehumidifying agent.)
 - Place of high temperatures (more than + 55 °C) and low temperatures (less than - 25 °C).
 - Place where there are corrosive gases.
 - Place subjected to dripping water.
 - Place with a lot of dust.
 - Place with insufficient ventilation.
 - Place subjected to strong magnetic or electric fields.
 - Place subjected to radiation.

13.2 The STP Control Unit

If the STP control unit (including cables) is not used for a long period (more than a few months), follow the precautions below:

- 1) Remove the internal battery from the STP control unit (see Section 9, "Internal Battery").



Always remove the battery when the STP control unit is not used for a long period.

- 2) Store the STP control unit in a horizontal position.
- 3) DO NOT store the STP control unit in the following places:
 - Place of high humidity.
(If it must be stored in a place of high humidity, insulate it from the outside and use a dehumidifying agent.)
 - Place of high temperature (more than + 55 °C) and low temperature (less than - 25 °C) (excluding the battery)



Storage temperatures of the battery range from - 20 to + 40 °C.

- 4) Place subjected to direct sunlight.
- 5) Place where there are corrosive gases.
- 6) Place subjected to dripping water.
- 7) Place with a lot of dust.
- 8) Place of insufficient ventilation.
- 9) Place subjected to strong magnetic or electric field.
- 10) Place subjected to radiation.
- 11) Place subjected to mist.
- 12) Place with electric noise.
- 13) Place with vibration.

13.3 Restarting Precautions

- 1) Stored for more than four months:
Charge internal batteries for 90 minutes or more under the "POWER ON" state before starting to operate the STP pump.
- 2) Stored for more than one year or when the date of replacement has passed:
Replace with new batteries.

14 Disposal

14.1 The STP Pump

Dispose of the STP pump as **industrial waste** according to the guidelines given by each national and/or local government.



When disposing of the STP pump, exhaust gases inside the STP pump thoroughly.
Residual gases may result in an accident when disposing of the STP pump.
If the STP pump has been used with reactive or corrosive gasses, always clean thoroughly before disposing of it to avoid any injury.
Confirm the characteristics of gas to be used, referring to the Material Safety Data Sheet (MSDS) you obtain from the gas supplier.



Seiko Seiki is not responsible for problems during or after disposal.

14.2 The STP Control Unit

Dispose of the STP control unit as **industrial waste** according to the guidelines given by each national and/or local government.



Remove the battery from the STP control unit.
Failure to do so may result in an accident or fire.
Always remove the battery from the STP control unit and strictly follow the guidelines for battery disposal in accordance with Section 14.3, "How to Dispose of The Battery."



Seiko Seiki is not responsible for problems during or after disposal.

14.3 The Battery

Dispose of or collect worn-out batteries in accordance with the guidelines given by each national and/or local government. If you procure batteries, dispose of them in accordance with the guidelines given by the battery manufacturer.



Pay attention to short-circuiting or leakage of the battery at their disposal.

To prevent the battery from short-circuiting, remove lead wires and connectors from the battery.

Cut lead wires one by one so as not to cause short-circuiting.

Coat the conductive part of the battery with tape or a similar material.



It is recommended to dispose of batteries after discharging them thoroughly.

Batteries manufactured by Japan Storage Battery Co., Ltd. will be collected by Japan Storage Battery Co., Ltd. For detailed information, contact Japan Battery Co., Ltd. or Seiko Seiki.

15 Troubleshooting

If an abnormality/error is found when using the STP pump, check it and take measures in accordance with the following procedures.

If you cannot trace it or if the STP pump does not function normally after troubleshooting, fill in the necessary information in the "STP PUMP PROBLEM CHECK SHEET" and fax it to Seiko Seiki.



After making sure that the STP pump stops thoroughly, and always turn OFF the primary power (Switch the breaker "OFF"), check probable causes and remove them.

15.1 Troubleshooting Immediately After An Abnormality/Error Occurs

1) **In case the "FAILURE" lamp lights due to an overload of the inverter (the STP pump continues rotating by inertia: FREE RUN state):**

<MANUAL OPERATION>

- i. Press the "MOTOR STOP" switch. The "FAILURE" lamp goes out and the FREE RUN state is reset.
- ii. Press the "MOTOR START" switch and press the "MOTOR STOP" switch again. The brake functions and the STP pump decelerates.
- iii. After the STP pump stops thoroughly (the "BRAKE" lamp goes out: the needle of the tachometer is in the red), turn OFF the "POWER ON/OFF" switch, switch the breaker "OFF," and remove probable causes of the abnormality/error.
- iv. Restart the STP pump and check if it operates correctly.

<REMOTE OPERATION>

- i. Slide the "MANUAL/REMOTE" changeover switch on the rear panel to "MANUAL."
- ii. Press the "MOTOR STOP" switch. The "FAILURE" lamp goes out and the FREE RUN state is reset.
- iii. Press the "MOTOR START" switch and press the "MOTOR STOP" switch again. The brake functions and the STP pump decelerates.
- iv. After the STP pump stops thoroughly (the "BRAKE" lamp goes out: the needle of the tachometer is in the red), switch the breaker "OFF," and remove probable causes of the abnormality/error.
- v. Restart the STP pump and check if it operates correctly.

2) In case the FREE RUN state is not reset after troubleshooting:

- i. Check the tachometer on the front panel.
- ii. If the needle is in the red, it means the STP pump has stopped.
Power OFF and switch the breaker "OFF."
- iii. If the needle is in the black, the STP pump is rotating.
Wait for it to enter the red. Then, power OFF and switch the breaker "OFF. "
- iv. Restart the STP pump and check if operates correctly.



DO NOT power OFF and switch the breaker OFF until the needle is in the red.



If the FREE RUN state cannot be reset, it takes approx. 8 to 10 hours to stop the STP pump (the needle is in the red) because it rotates by inertia. To stop the STP pump quickly, close the vacuum valve at the outlet port flange and introduce gas from the purge port into the STP pump.

3) Other Cases:

After the STP pump stops thoroughly, power OFF, switch the breaker "OFF" and remove probable causes of the abnormality/error. Then, restart the STP pump and check if it operates correctly.

15.2 Abnormalities When Powering ON

(When any "Abnormality/Error Warning" lamp lights, see Section 15.5 "When Any Abnormality/Error Warning Lamp Lights.")

Table 15.1 Troubleshooting After Powering ON

No.	Symptom	Probable Cause	Countermeasures	Referred Section
1	The "POWER ON/OFF" switch built-in lamp (green LED) does not light, when powering ON.	(1) Incorrect connection of the power cable.	Connect the power cable correctly.	4.4.2
		(2) Blown fuses F3, F4.	Replace blown fuses (250 V, 5 A).	4.1.3 12.3
		(3) Abnormal power voltage	Set the voltage to the rated voltage $\pm 10\%$.	4.4.2 16.2
		(4) Power failure.	Check whether or not a power failure has occurred.	6.1.1

15.3 Abnormalities When Performing The STP Pump Start Operation

(When any "Abnormality/Error Warning" lamp lights, see Section 15.5 "When Any Abnormality/Error Warning Lamp Lights.")

Table 15.2 Troubleshooting When Performing The STP Pump Start Operation

No.	Symptom	Probable Cause	Countermeasures	Referred Section
1	The "ACCELERATION" lamp does not light.	(1) TB3 INHIBIT (5) - (7) for Rotation INHIBIT Signal Input are opened.	When this function is not used, short the circuit between terminals (5) - (7). If these terminals are opened, the STP pump will not rotate after performing start operation.	8.2
		(2) The "MANUAL/REMOTE" changeover switch is not in the correct position.	Slide the "MANUAL/REMOTE" changeover switch on the rear panel of the STP control unit to the correct position.	4.1.2 5.5 5.6
		(3) Blown fuses F11, 12 (only REMOTE operation).	Replace the blown fuses (250 V, 0.1 A).	4.1.3 8.4 12.3

15.4 Abnormalities While the STP Pump is Rotating

(When any "Abnormality/Error Warning" lamp lights, see Section 15.5 "When Any Abnormality/Error Warning Lamp Lights.")

Table 15.3 Troubleshooting While the STP Pump Is Rotating

No.	Symptom	Probable Causes	Countermeasures	Referred Section
1	The "NORMAL OPERATION" lamp does not light approx. 15 minutes after performing start operation.	(1) Insufficient pressure at the inlet port.	Use the maximum working pressure or less.	3.3.4 16.1
		(2) Insufficient pressure at the outlet port.	Use the allowable backing pressure or less.	3.3.4 16.1
		(3) Leakage of the piping system.	Check piping.	3.3.4
		(4) Failure in the auxiliary pump.	Check the auxiliary pump for its capacity and START state. (use a pump with the recommended capacity or more).	3.3 16.1
		(5) Incorrect connection of the motor connection cable.	Connect the motor connection cable correctly. If the cable connector is not locked, lock it securely.	4.4.2

No.	Symptom	Probable Causes	Countermeasures	Referred Section
2	The STP pump stops.	(1) Baking temperature overheat.	Set the temperature to 120 or lower.	7.3
		(2) Insufficient cooling.	Always cool during baking or gas suction.	7.2
		(3) Power failure.	Check if power has failed.	6.1.1
		(4) Over vibration (5) (vibration 100 μm p-p or more).	After the STP pump stops thoroughly, power OFF and remove external vibration so as not to transmit it to the STP pump.	6.1.3
		(6) Overheating inside the STP control unit. 1) Ambient temperature 2) Insufficient cooling of the STP control unit.	Remove heat source or shield for air route. 1) Keep ambient temperature 40 °C or lower.	4.2.1
			2) Remove obstacles at the ventilation port. If the air cooling fan is broken, contact Seiko Seiki.	4.2.2 12.2
		(7) Improper pressure of the inlet port.	Use the maximum working pressure or less.	3.3.4 16.1
		(8) Improper pressure of the outlet port.	Use the allowable backing pressure or less.	3.3.4 16.1
3	Rotor falls during operation.	(1) Failure of the STP connection cable.	Inspection is needed. Contact Seiko Seiki.	4.4.2
		(2) Failure of the battery.	Inspection is needed. Contact Seiko Seiki.	9 10
4	Ultimate pressure is insufficient.	(1) Failure of the auxiliary pump.	Check the auxiliary pump for its capacity and START state. (use a pump with the recommended capacity or more).	3.3 16.1
		(2) Leakage of the piping system.	Check the piping system.	3.3.4
		(3) Residual molecule.	If the main composition is H ₂ or H ₂ O, perform baking; if it is other than H ₂ or H ₂ O, clean the inside of the vacuum equipment (If gases remain inside the STP pump, contact Seiko Seiki when it is needed to be cleaned).	7.3 12.4

15.5 When Any Abnormality/Error Warning Lamp Lights

When any Abnormality/Error Warning lamp lights, check which lamp is being lit and see Table 15.5 for which procedure No. to follow.

Then, follow the steps of that procedure No. (shown in Tables 15.6 to 15.8) to remove the problem (for the names and positions of the "Abnormality/Error Warning" lamps, see Figures 4.1 and 4.3).

Table 15.4 Cross Reference of Items of Abnormality Warning Lamps

OVER TEMPERATURE	BATTERY OPERATION	FAILURE	EMERGENCY OPERATION	BATTERY NG (front panel rear side)	PROCEDURE No.
	—			—	No. 1
	—		—	—	No. 2
—		—		—	No. 3
—	—		—	—	No. 4
—	—	—		—	No. 5
—	—	(When the power is turned on again, this lamp goes out.)			No. 6

- : The lamp is being lit.
- : The lamp is not being lit.
- : The lamp may light.

 **CAUTION**

When checking the " BATTERY NG" lamp, turn OFF the primary power (Switch the breaker "OFF"), then open the front panel. After opening the front panel, turn ON the primary power (Switch the breaker "ON"). Failure to do so may result in electric shock or product damage due to short-circuiting of the internal circuit.

 **NOTICE**

The "BATTERY NG" lamp remains lit until it is reset even after the primary power is turned OFF (the breaker is switched "OFF").

Table 15.5 Troubleshooting When Any of Abnormality/Error Warning Lamp Lights

PROCEDURE No.	Lamp Being Lit	Probable Causes	Countermeasures	Referred Section
No.1	"OVER TEMPERATURE" "FAILURE" "EMERGENCY OPERATION"	(1) Incorrect connection of the STP connection cable.	Connect cables correctly. If the cable connector is not locked, lock it securely.	4.4.2
No.2	"OVER TEMPERATURE" "FAILURE"	(1) Overheat inside the STP pump: 1) Overheat during baking. 2) Insufficient cooling. 3) Leakage of the vacuum piping system. 4) Repetitious start/stop operations.	1) Set the temperature of the baking heater to 120 °C or lower. 2) At the time of baking or gas suction, always cool the STP pump. 3) Check the piping system for leakage. 4) Repetitious start/stop operations may cause the STP pump to overheat.	7.3 7.2 3.3.4 5.2
No.3	"BATTERY OPERATION" "EMERGENCY OPERATION"	(1) Power failure.	Check a power failure.	6.1.1
No.4	"FAILURE"	(1) Incorrect connection of the emergency vent. valve cable.	Connect the cable correctly. If the cable connector is not locked, lock it securely.	4.4.2
		(2) When the rated operation does not start approx. 15 minutes after start operation is executed: When the ACCELERATION state continues for approx. 15 minutes: 1) Insufficient pressure at the inlet port. 2) Insufficient pressure at the outlet port. 3) Leakage of the piping system. 4) Failure of the auxiliary pump. 5) Incorrect connection of the motor connection cable.	1) Use the maximum working pressure or less. 2) Use the allowable backing pressure or less. 3) Check the piping system for leakage. 4) Check the auxiliary pump for its capacity and START state. (use a pump with the recommended capacity or more). 5) Connect the cable correctly. If the cable is not locked, lock it securely.	6.1.4 3.3.4 16.1 3.3.4 3.3.4 3.3 16.1 4.4.2

STP-H600/H1000 Series Instruction Manual

PROCEDURE No.	Lamp Being Lit	Probable Causes	Countermeasures	Referred Section
No.4	"FAILURE"	(3) Overheating inside the STP control unit: 1) Ambient temperature.	1) Set the ambient temperature to 40 °C or lower.	4.2.1
		2) Insufficient cooling of the STP control unit.	2) Remove obstacle from the ventilation port. If the air cooling fan is broken, contact Seiko Seiki.	4.2.2 12.2
		(4) Peripheral equipment abnormality (when peripheral equipment is connected between TB3 R.P. THER (1)–(3)).	Remove abnormalities from peripheral equipment.	8.2
		(5) TB3 R. P. THER (1)–(3) are opened. (when peripheral equipment is not connected between TB3 R. P. THER (1)–(3)).	Short the circuit between terminals (1)–(3).	8.2
		(6) Insufficient charging or deterioration of the battery.	Check that the battery is fully charged. If the battery is not charged, charge it. Check the battery for deterioration and the next replacement date. If the battery deteriorates or its replacement date has passed, replace it.	9 10
		(7) Incorrect connection of the battery.	Check that external or internal batteries are correctly connected.	9 10
		(8) Blown fuses F8, F9 (for battery protection).	Replace the blown fuses (250 V, 10 A).	12.3
No.5	"EMERGENCY OPERATION"	(1) Different model name or No. on the name plate.	Check that the model name, serial number and cable length of the STP pump, the STP control unit and the STP connection cable are the same.	Safety Precautions 4.4.2
		(2) Excessive external vibration (vibration of 100 μm p-p or more).	After the STP pump stops thoroughly, power OFF and remove external vibration so as not to transmit it to the STP pump.	6.1.3

PROCEDURE No.	Lamp Being Lit	Probable Causes	Countermeasures	Referred Section
No.6	"FAILURE" "BATTERY NG" (inside the front panel) ("EMERGENCY OPERATION" lamp may light)	(1) Insufficient charge or deterioration of the battery.	1) Check whether or not the battery is fully charged. If the battery is not sufficiently charged, charge it. 2) Check the deterioration and the replacement date of the battery. If the battery has deteriorated or the replacement date has passed, replace the battery with a new one. 3) After taking steps 1) and 2) above, reset BATTERY NG.	9 10

 **CAUTION**

When checking the " BATTERY NG" lamp, turn OFF the primary power (Switch the breaker "OFF"), then open the front panel. After opening the front panel, turn ON the primary power (Switch the breaker "ON"). Failure to do so may result in electric shock of product damage due to short-circuiting of the internal circuit.

 **NOTICE**

The "BATTERY NG" lamp remains lit until it is reset even after the primary power is turned OFF (the breaker is switched "OFF").

16 Specifications and Accessories

16.1 Specifications for the STP Pump

Table 16.1 Specifications for the STP Pump

Item		STP-H600	STP-H1000
Flange size*1	Inlet port flange	ICF203/VG150/ISO160	ICF253/VG200/ISO200
	Outlet port flange	KF40	
Pumping speed	N ₂ L/s	600	1000
	He L/s	550	900
	N ₂ L/s	500	800
Compression ratio	N ₂	>10 ⁸	
	He	10 ⁴	
	N ₂	10 ³	
Ultimate pressure	Pa (Torr)	10 ⁻⁷ (10 ⁻⁹) order (after baking)	
Maximum working pressure Pa (Torr)	When cooled water:	67 (0.5)	
	When cooled air:	5.3 (0.04)	
	When cooled natural air:	0.9 (0.007)	
	When TMS unit is used:	13(0.1)	
Allowable backing pressure Pa (Torr)	When cooled water:	400 (3)	
	When TMS unit is used:	400 (3)	
	When cooled air: When cooled natural air:	267 (2)	
Rated speed	rpm	35,000	
Starting time	min	6	
Stopping time	min	6	
Vibration	μ m O-P	< 0.01 (at 35,000 rpm)	
Noise	dB	< 50 (at 35,000 rpm)	
Baking temperature	°C	< 120	
Lubricating oil		Not necessary	
Installation position		Free	
Cooling method*2		Water cooled, Air cooled, Natural air cooled	
Recommended auxiliary pump	L/min	240	
Mass*3	kg	31	32
Ambient temperature range	°C	0 to 40	
Storage temperature range	°C	- 25 to + 55	

Values shown in the above table are typical. They are not guaranteed.

*1 : ICF (JVIS) VG, KF (JIS)

*2 : Varies depending upon the operation pressure range.

*3 : Mass is a value of state that the only standard accessory was installed. (except the optional accessory)

16.2 16.2 Specifications for the STP Control Unit

Table 16.2 Specifications for the STP Control Unit

Item		Specifications
Input voltage	V AC	200 to 240 \pm 10%
Input power	At start:	kVA 2.6
	Under rated operation:	kVA 1.0 to 2.6
Input frequency	Hz	50/60 \pm 2
Input phase		Single phase
Rated current of main breaker	A	20
Motor drive system		3-phase transistor-inverter
Output voltage under rated operation(3-phase)	V AC	52
Output frequency under rated operation	Hz	584
Ambient temperature range		0 to 40
Storage temperature range		- 25 to + 55 (excluding a battery)
Battery storage temperature range		- 20 to + 40
Mass ^{*1}	kg	40
Battery used		12 V 2Ah x 4 (Japan Storage Battery Co., Ltd./Small-Sized Sealed Lead-Acid Battery/PORTALAC series PE12V2WS)
Operation switches		<p>[Front Panel]</p> <ul style="list-style-type: none"> • POWER ON/OFF (Illuminated alternate push button switch, black/green) • MOTOR START (Momentary push button switch, black) • MOTOR STOP (Momentary push button switch, red) • HEATING ON/OFF (Illuminated alternate push button switch, black/green) <p>[Rear Panel]</p> <ul style="list-style-type: none"> • MANUAL/REMOTE Changeover (Toggle switch)
Panel indication lamps		<ul style="list-style-type: none"> • ACCELERATION (Green LED) • NORMAL OPERATION (Green LED) • BRAKE (Yellow LED) • EMERGENCY OPERATION (Red LED) • FAILURE (Red LED) • OVER TEMPERATURE (Red LED) • BATTERY OPERATION (Red LED) <p>[Switch built-in Lamps]</p> <ul style="list-style-type: none"> • POWER ON (POWER ON/OFF, green) • HEATING ON (HEATING ON/OFF, green)

*1 : Mass is a value of state that the only standard accessory was installed. (except the optional accessory)

Item	Specifications
Input/output terminal	<ul style="list-style-type: none"> • AC POWER TB1 (3 pins) • P.CONNECTOR CON5A (45 pins) • INVERTER OUTPUT CON2A (5 pins) • LEAK VALVE CON8A (8 pins) • I/O TB2 (20 pins) • DC I/O TB3 (10 pins) • START STOP TB5 (3 pins) • START/STOP TB6 (2 pins) • EXT. BATTERY CON9 (2 pins)
Input/output cables	<ul style="list-style-type: none"> • Primary power cable • STP connection cable • Motor connection cable • Emergency vent. valve cable • Ground cable
Safety functions	<ul style="list-style-type: none"> • Magnetic bearing abnormality/error detection (Rotor vibration: 100 μ m p-p or more) • STP pump overheat detection (Motor: 110 over) • Inverter overload detection (Inverter current: 40 A over, instantaneous, A over for 15 minutes) • Battery abnormality/error detection (Battery terminal voltage: 42 V under) • Power failure detection (Detects power failure of over about 2 seconds) • STP pump overspeed detection (37500 rpm over) • STP control unit overheat detection (90 over) • Brake failure detection

16.3 Accessories

Table 16.3 Accessories

Item	Q'ty	Remarks
STP control unit	1	
Primary power cable*1	1	
STP connection cable*1	1	
Motor connection cable*1	1	
Ground cable*1	1	
Inlet port cover	1	
Outlet port cover	1	
STP connector cover	1	
Motor connector cover	1	
Leg	8	4 legs are attached to the STP pump
Rubber foot for lug	4	
Emergency vent. valve	1	With a one-sided connector cable*1
Emergency vent. valve clamping ring	1	KF*210
Emergency vent. valve O-ring washer	1	KF*210
Blank flange for purge port	1	KF*210
Purge port clamping ring	2	KF*210
Purge port O-ring washer	2	KF*210
T-piping	1	KF*210
External battery connection plug	1	
Spare fuses	250 V, 5 A	2 F3, 4
	250 V, 10 A (arc-extinguishing fuses)	2 F5, 6, 7, 8, 9
	250 V, 0.1 A	2 F11, 12
Instruction Manual	1	

16.4 Recommended Spare Parts

Table 16.4 Recommended Spare Parts

Item	Model and Manufacturer	Specifications
Fuses for F3, 4	MF60-NR5, 5 A, 250 V (TOYO FUSE CO., LTD)	5 A, 250 V, Normal acting fuse Φ6.35 × 30 mm
Fuses for F5 to 9	MF60-NR10-S, 10 A, 250 V (TOYO FUSE CO., LTD)	10 A, 250 V, Normal acting fuse (arc-extinguishing fuses) Φ6.35 × 30 mm
Fuses for F11, 12	MF60-NR0.1, 0.1 A, 250 V (TOYO FUSE CO., LTD)	0.1A, 250 V, Normal acting fuse Φ6.35 × 30 mm
Internal batteries	PE12V2WS (Japan Storage Batteries Co., Ltd.)	Nominal voltage: 12 V Rated capacity (20-hour rate): 2Ah



Do not use parts other than those recommended in the above table.
If you use these parts, contact Seiko Seiki before use.

*1 :The standard cable length is 5 m.

*2 :JIS

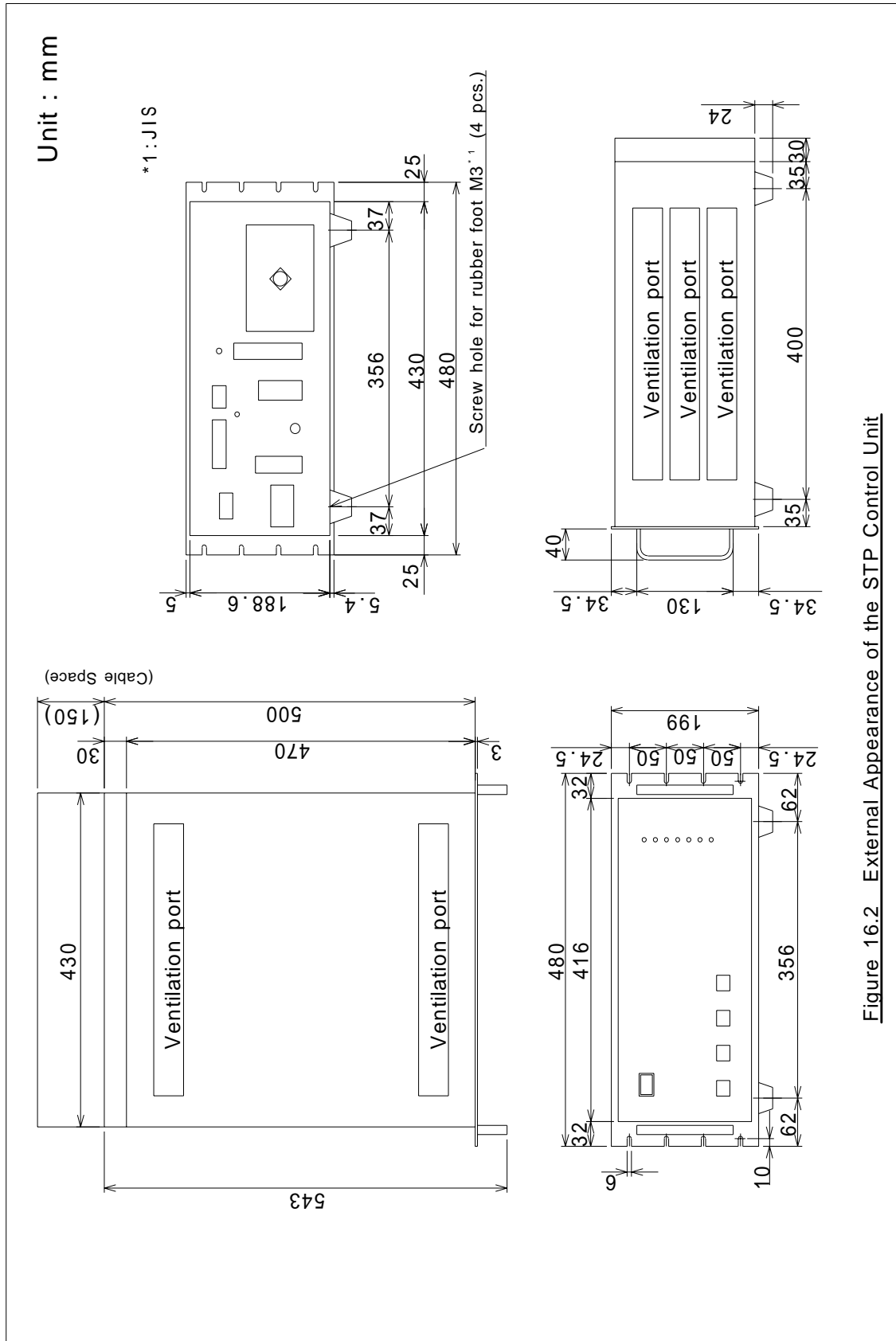

Figure 16.2 External Appearance of the STP Control Unit

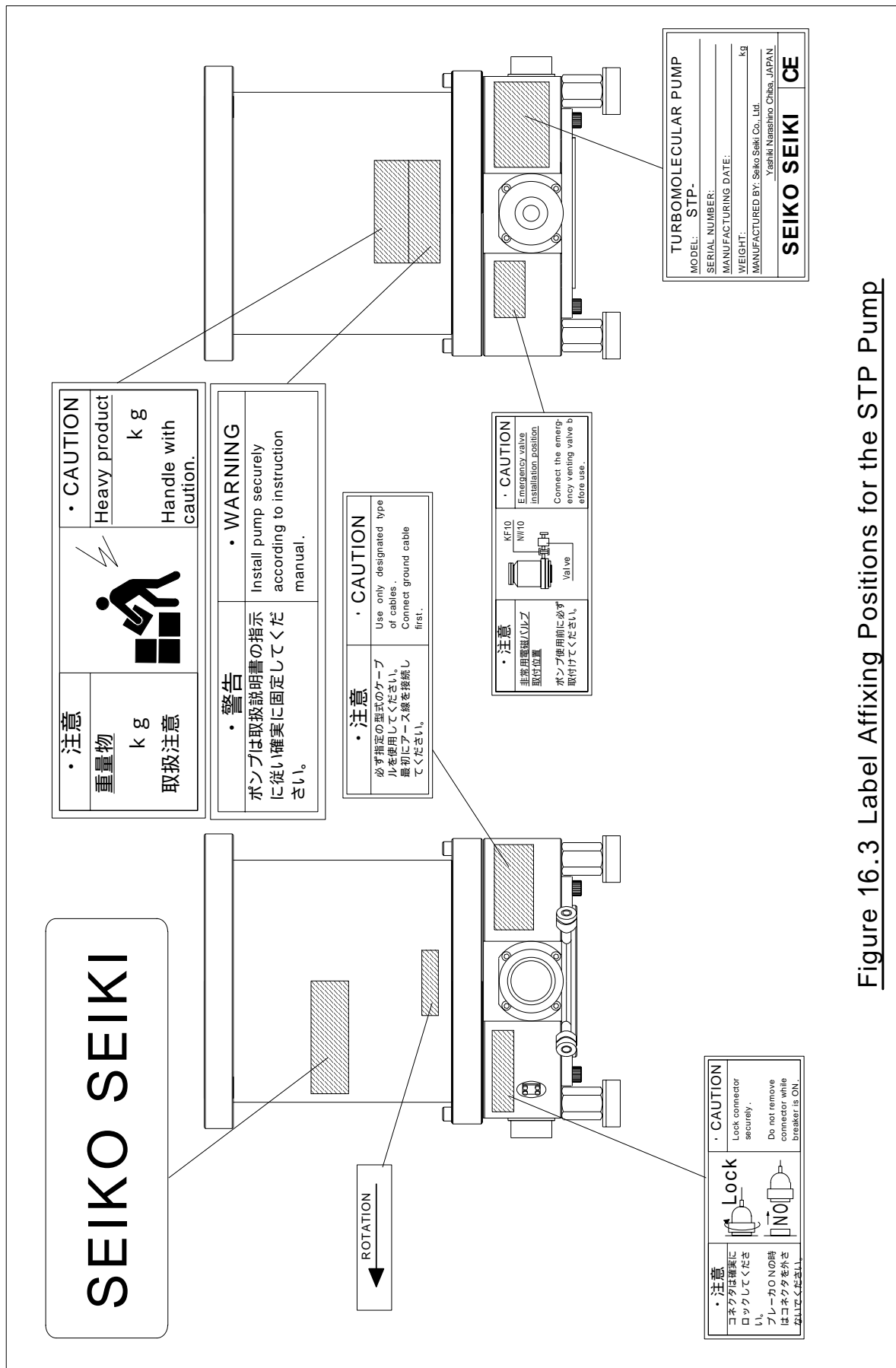

Figure 16.3 Label Affixing Positions for the STP Pump

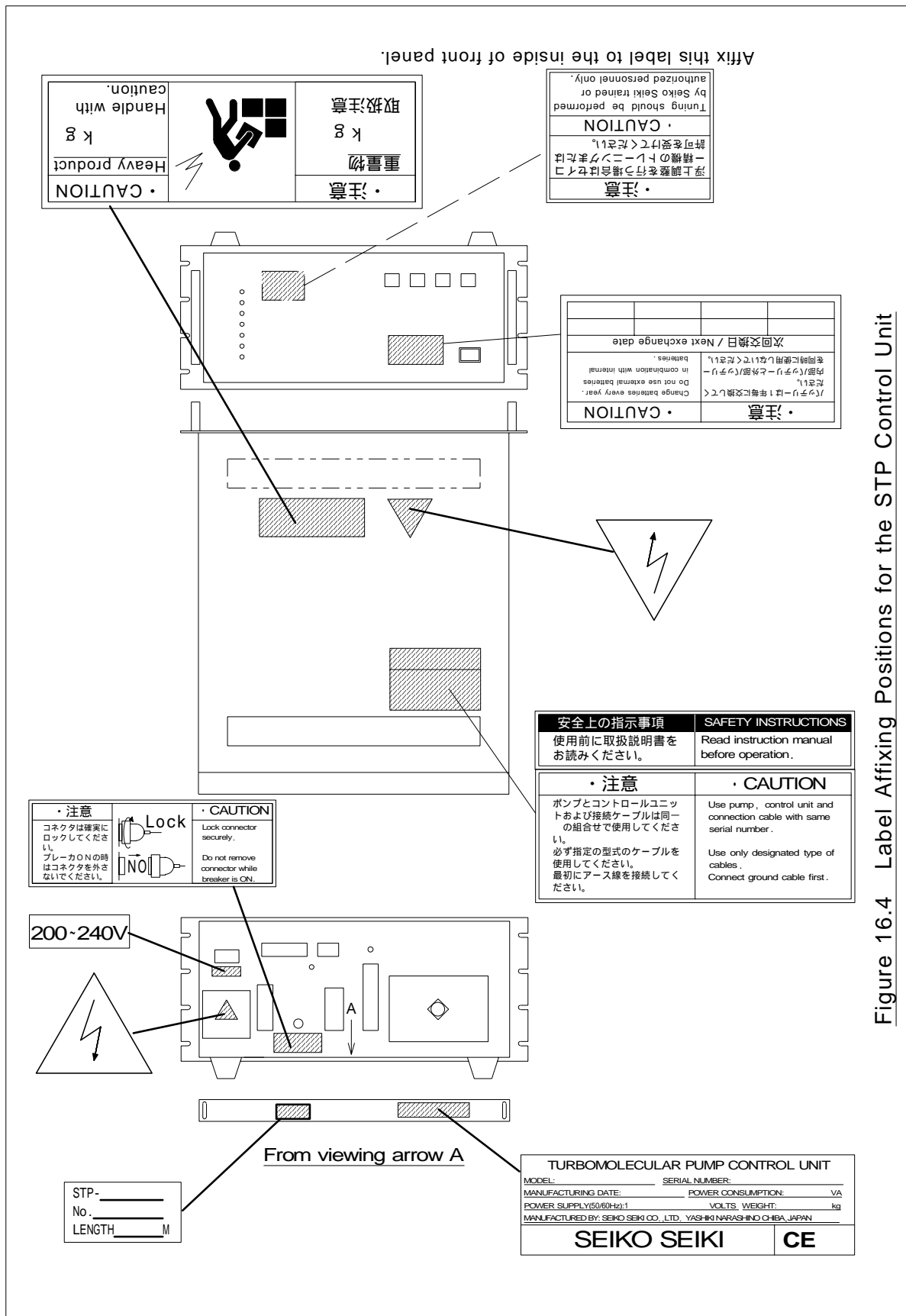
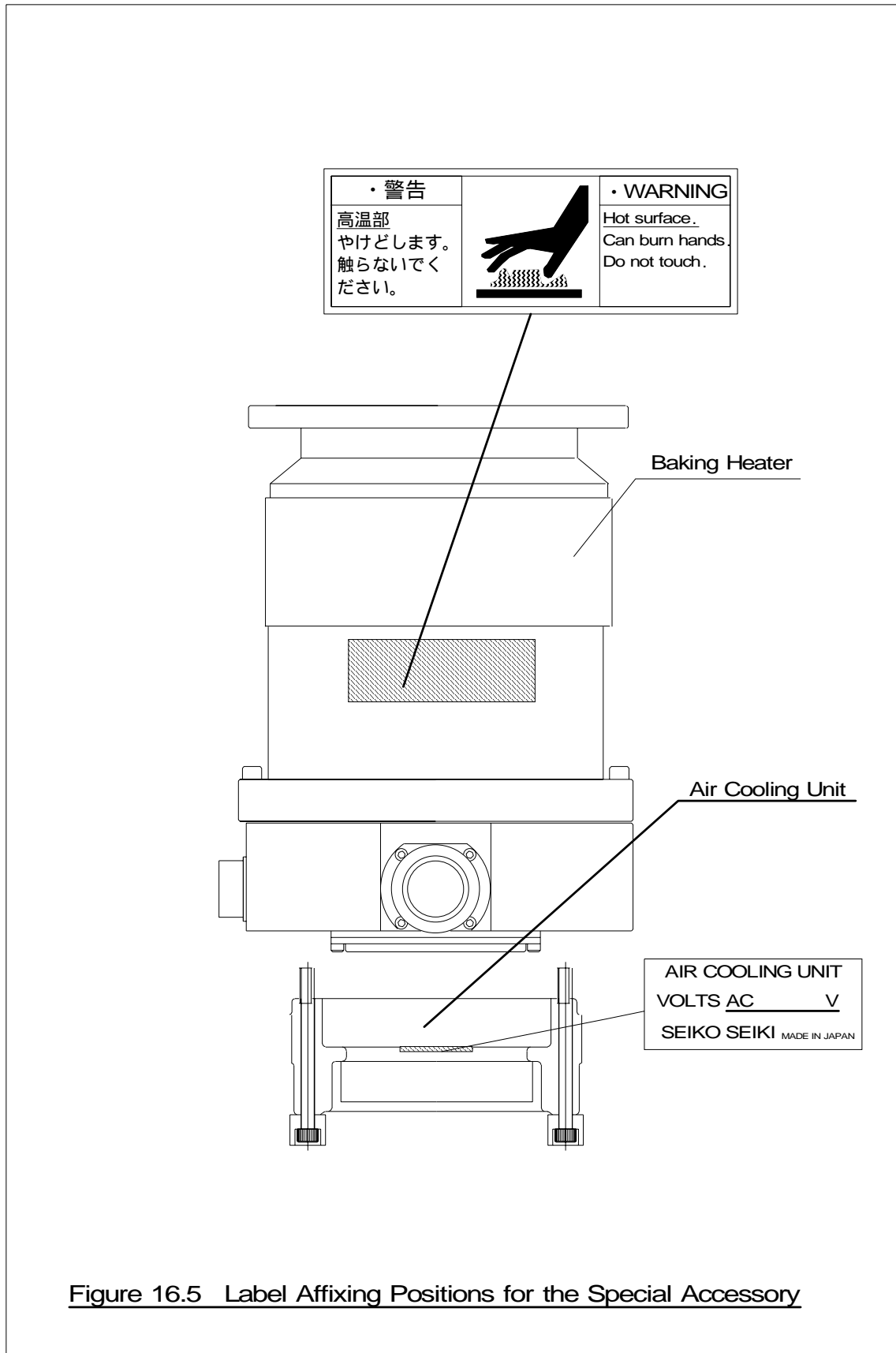

Figure 16.4 Label Affixing Positions for the STP Control Unit



STP PUMP PROBLEM CHECK SHEET

Contact your nearest Seiko Seiki's office shown in the rear cover.

To : Company Name : _____ Date : _____
 Contact Name : _____
 TEL. Number : _____
 FAX. Number : _____
 Address : _____

From: Customer Name : _____ Date : _____
 Person in charge : _____
 TEL. Number : _____
 FAX. Number : _____
 Address : _____

Model Name : STP-	Inlet Flange Type :	Length of Connection Cable: m	Input Voltage: V
M/C No. :	Manufacturing Date :	Other:	

Check Items	State/Result	STATE OF PROBLEM (while the vacuum chamber is in operation, etc.) OTHER INFORMATION
Abnormality Warning (Check lamps being lit)	OVER TEMPERATURE	
	BATTERY OPERATION	
	FAILURE	
	EMERGENCY OPERATION	
	BATTERY NG (inside panel)	
Pump	Noise Yes / No	
	Vibration Yes / No	
	Heat Yes / No	
	Choke Water Yes / No	
	Deposition Yes / No	
Control Unit	Next Battery Replacement Date YY / MM	
	Power Failure Time Min.	
	Blown Fuses Yes / No (Fuse No. F)	
	Heat Yes / No	
Other	Used Gas	
	Pump Installation Position Vertically / Horizontal Upside-down Other ()	
	Leakage Yes / No	
	TMS Unit Yes / No	

Seiko Seiki Comment :
 Date . . Name Job No.

UNIT CONVERSION TABLE

Length

m	cm	mm	inch
1	100	1.00×10^3	39.4
0.01	1	10.0	0.394
1×10^{-3}	0.10	1	39.4×10^{-3}
25.4×10^{-3}	2.54	25.4	1

Mass

g	kg	lb.
1	1.00×10^{-3}	2.20×10^{-5}
1×10^3	1	2.20
454	0.454	1

Pressure

Pa	Torr	kgf/cm ²
1	7.50×10^{-3}	1.02×10^{-5}
133	1	1.36×10^{-3}
9.81×10^4	736	1

Sales Office (Japan)

Seiko Instruments Inc. Vacuum Innovative Products Sales Department
1-8 Nakase, Mihama-ku, Chiba-shi, Chiba 261-8507 JAPAN
Telephone: <Vacuum Innovative Products Sales Department, Direct>
Domestic 043-211-1401
International + 81-43-211-1401
Facsimile: Domestic 043-211-8075
International + 81-43-211-8075

Manufacturer, Sales Office (Japan)

Seiko Instruments Inc. Vacuum Innovative Products Division
4-3-1 Yashiki, Narashino-shi, Chiba 275-0004 JAPAN
Telephone: <Vacuum Innovative Products Service Section, Direct>
Domestic 047-475-3123
International +81-47-475-3123

<Company main>

Domestic 047-475-3111
International +81-47-475-3111
Facsimile: Domestic 047-471-1544
International +81-47-471-1544

Supplier:

Seiko Instruments Inc.
1-8 Nakase, Mihama-ku, Chiba-shi, Chiba 261-8507 JAPAN
Telephone: national 043-211-1401 (VI Sales Sec., Direct)
intern. + 81-43-211-1401
Facsimile: national 043-211-8075
intern. + 81-43-211-8075

Supplier:

Seiko Instruments USA
1130 Ringwood Court
San Jose, CA 95131 U.S.A.
Telephone: national 408-922-5932
intern. +1-408-922-5932
Facsimile: national 408-922-1959
intern. +1-408-922-1959

Supplier:

Seiko Instruments Belgium S.A
Av. De Messidor 202 1180 Bruxelles, Belgium
Telephone: national 02-346-6274
intern. + 32-2-346-6274
Facsimile: national 02-347-5268
intern. + 32-2-347-5268